

WORK^{PRO} L I F T E R S

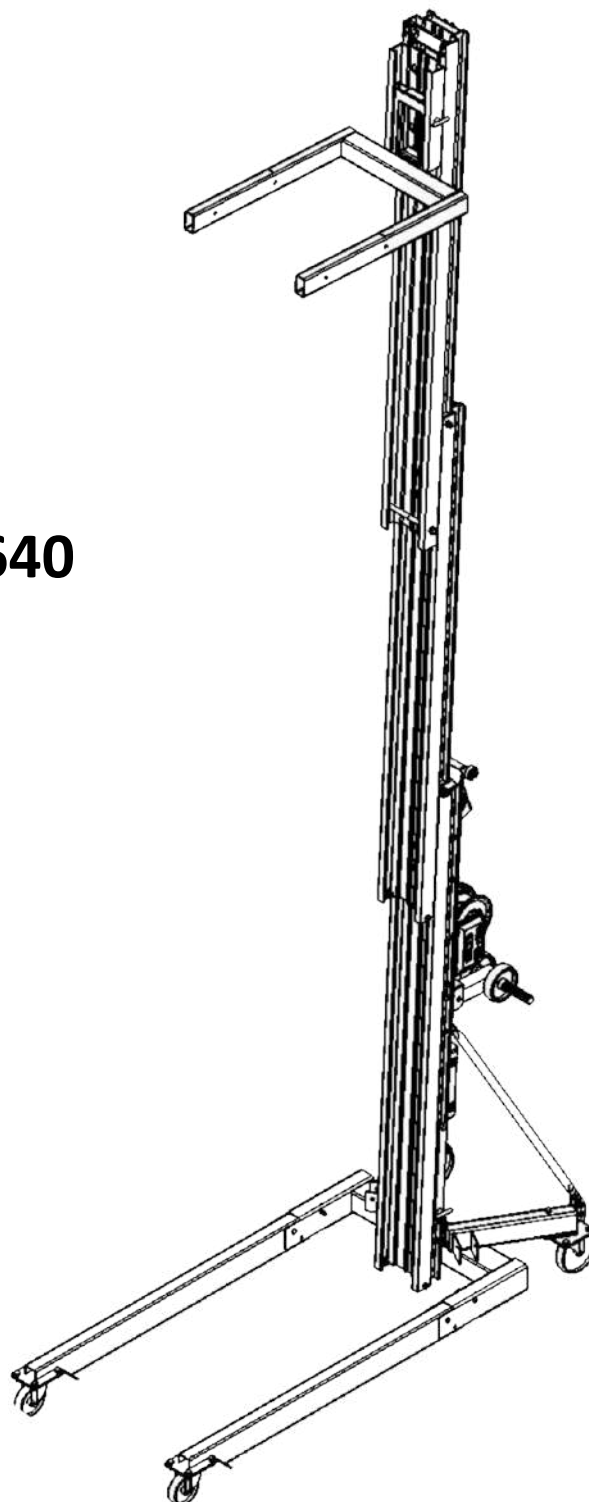

USER MANUAL FOR: CT 640





WORKPRO LIFTERS.
C/Traginers, 4. P.I. - L'Alter,
Alcasser - Valencia SPAIN
Telf +34 961260168
www.worklifters.com

IMPORTANT

Carefully read and understand all points and aspects of this manual. Lifting loads irresponsibly can cause lethal accidents. Installation of lifting systems and proper use are only responsibility of the user.

It is recommended to attach this manual with the lifter system used.

In case of doubt, consult the technical department of Work Lifters.

ILLUSTRATION INDEX

Figure 1	3
Figure 2	3
Figure 3	3
Figure 4	3
Figure 5	4
Figure 6	4
Figure 7	4
Figure 8	4
Figure 9	5
Figure 10	5
Figure 11	5
Figure 12	5
Figure 13	6
Figure 14	6
Figure 15	6
Figure 16	6
Figure 17	7
Figure 18	8
Figure 19	8
Figure 20	8
Figure 21	8
Figure 22	9
Figure 23	9
Figure 24	9
Figure 25	10
Figure 26	10
Figure 27	10
Figure 28	10
Figure 29	11
Figure 30	12
Figure 31	13
Figure 32	14
Figure 33	15
Figure 34	15
Figure 35	16
Figure 36	16
Figure 37	17

WARNING ICONS



RULES AND SAFETY USE

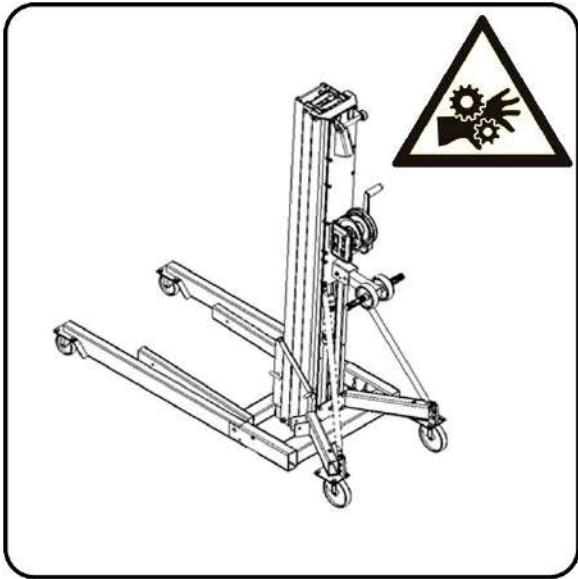

Figure 1
Keep hands and fingers away from moving parts of the lifter.

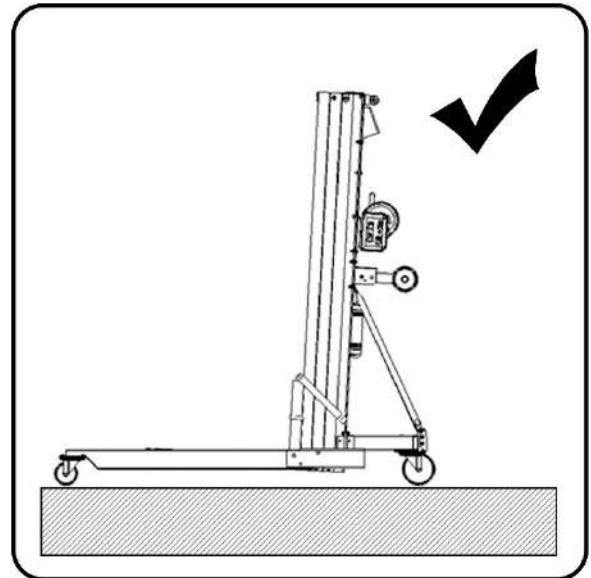

Figure 3
Do not lift the lifter without proper leveling. To lift a load, the lifter must always be stabilized. The wheels must not touch the ground.

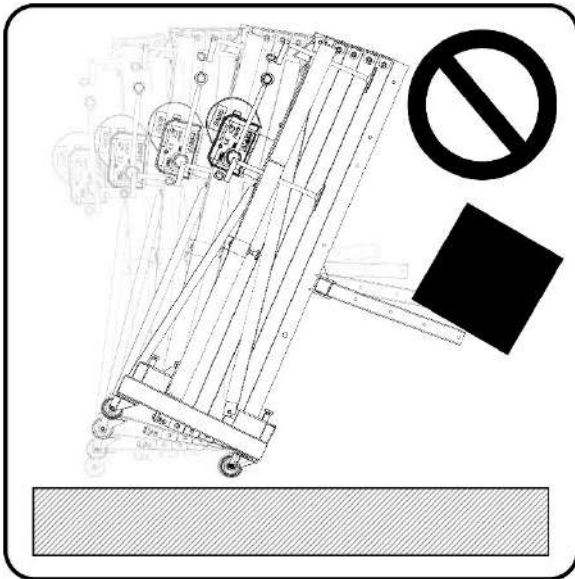

Figure 2

Not charge the lifter without the stabilizer's legs.

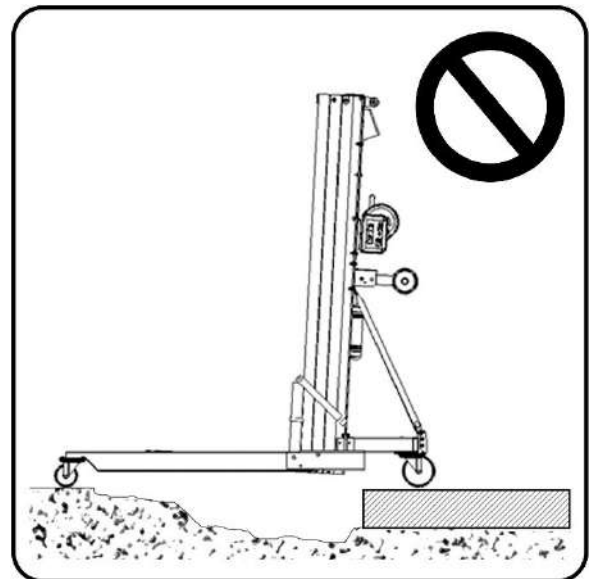

Figure 4

Place the lifter on a stable surface.

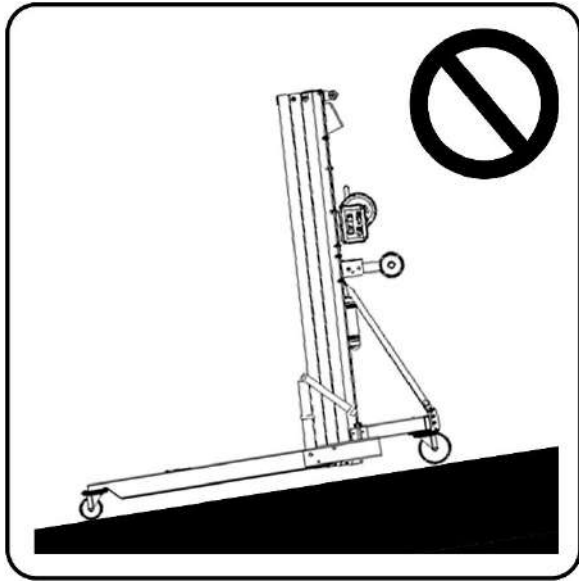

Figure 5

Do not use the lifter on inclined surfaces that require pieces to level the lifter.

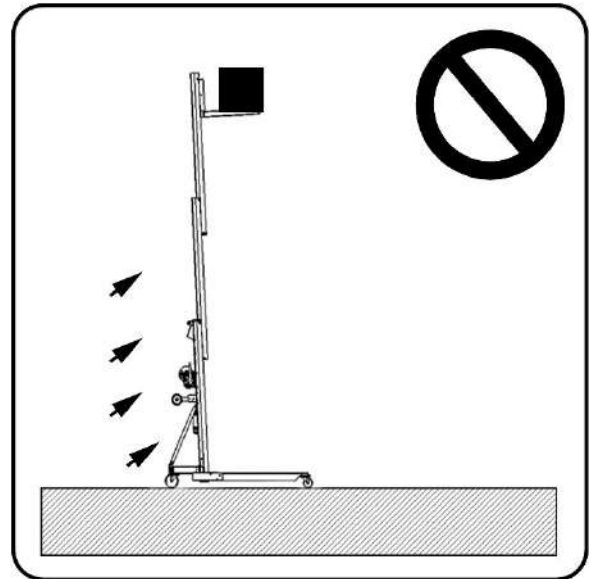

Figure 7

Never move a load without leveling the lifter before.

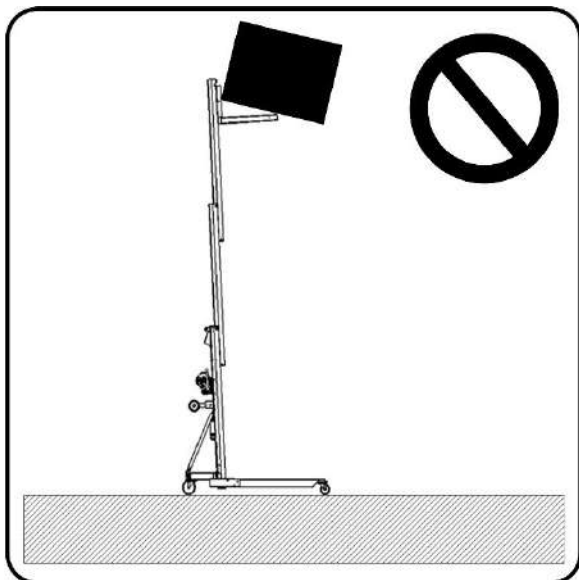

Figure 6

Before placing a load, make sure that the load never exceeds the maximum allowed. Consult the section of load data



Do not use ladders on the lifter or leaning against it.

Figure 8

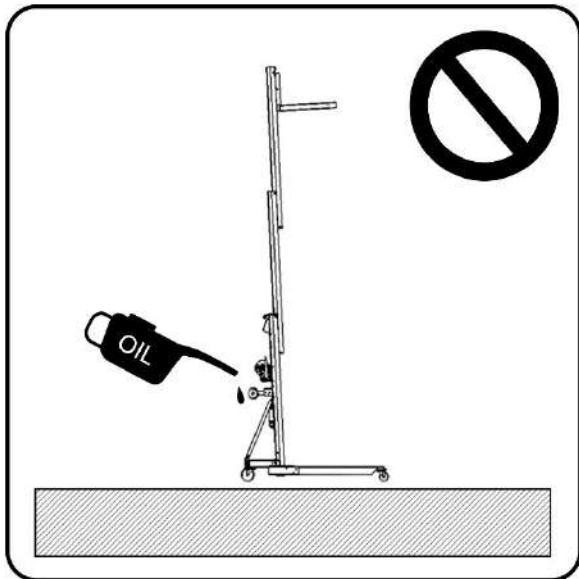

Figure 9

Not grease and lubricate the mechanism of the winch and the pulleys of the masts.

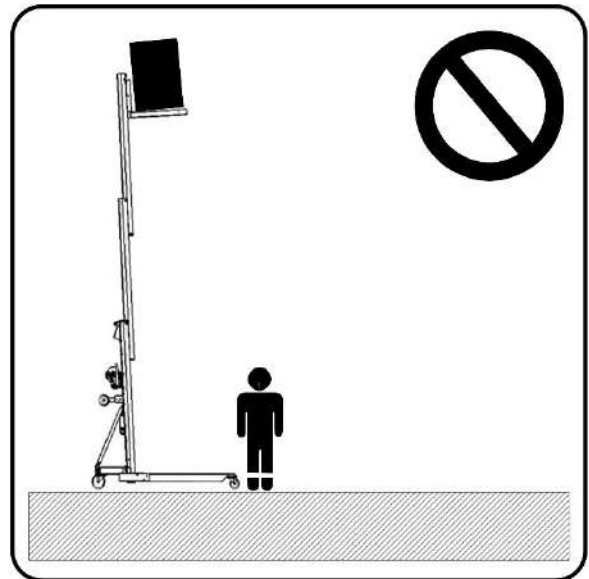

Figure 11

During the rise or descend load process, do not stand under the load. The load must be secured to the lifter in order to prevent that it cannot fall down.

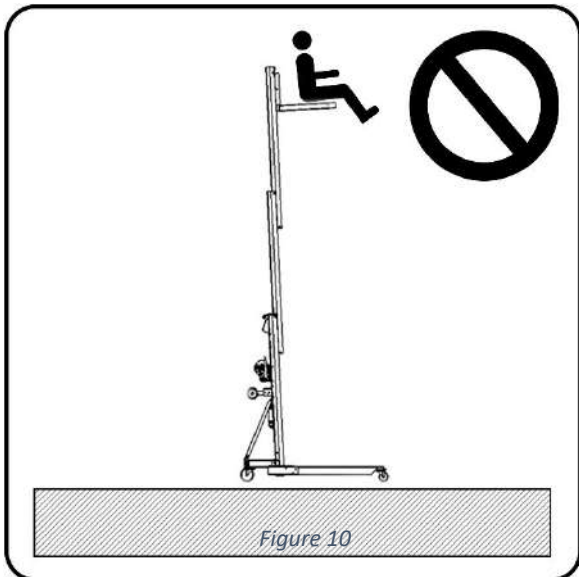

Figure 10

Not allowed to lift people or animals.



Figure 12

Verify that the lifter is beyond the reach of power lines.

The lifter is not electrically insulated and can transmit currents of power lines.

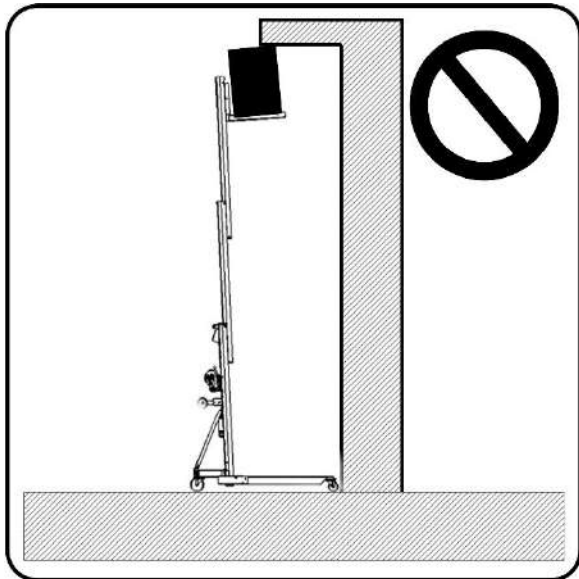

Figure 13

Not lift a load if there is danger of collision. Take at least 1.5 meters on any direction to lift the load safely.

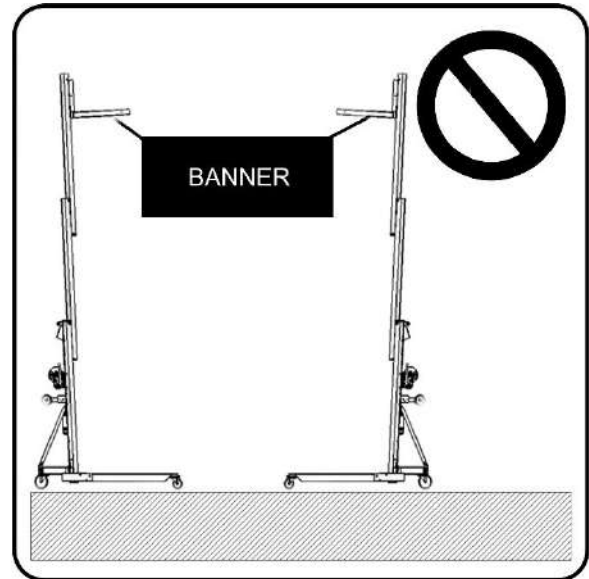

Figure 15

Do not use the lifter as a support of banners or another type of decoration with strong wind that can destabilize the lifter and make it falls.

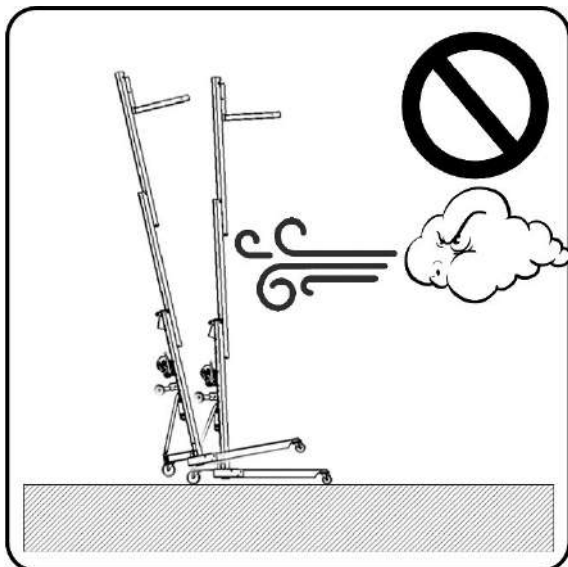

Figure 14

L The lifter can be used outdoor if the wind speed is low and If it doesn't put the installation in risk. **The installation is always under responsibility of the owner.**

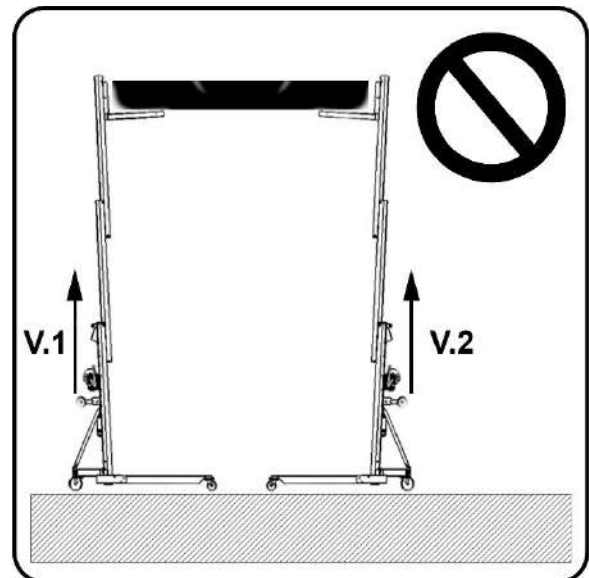

Figure 16

Do not lift structures that require more than one lifter at different speeds.

$V1 \neq V2$ No lift

$V1 = V2$ Ok

PARTS IDENTIFICATION

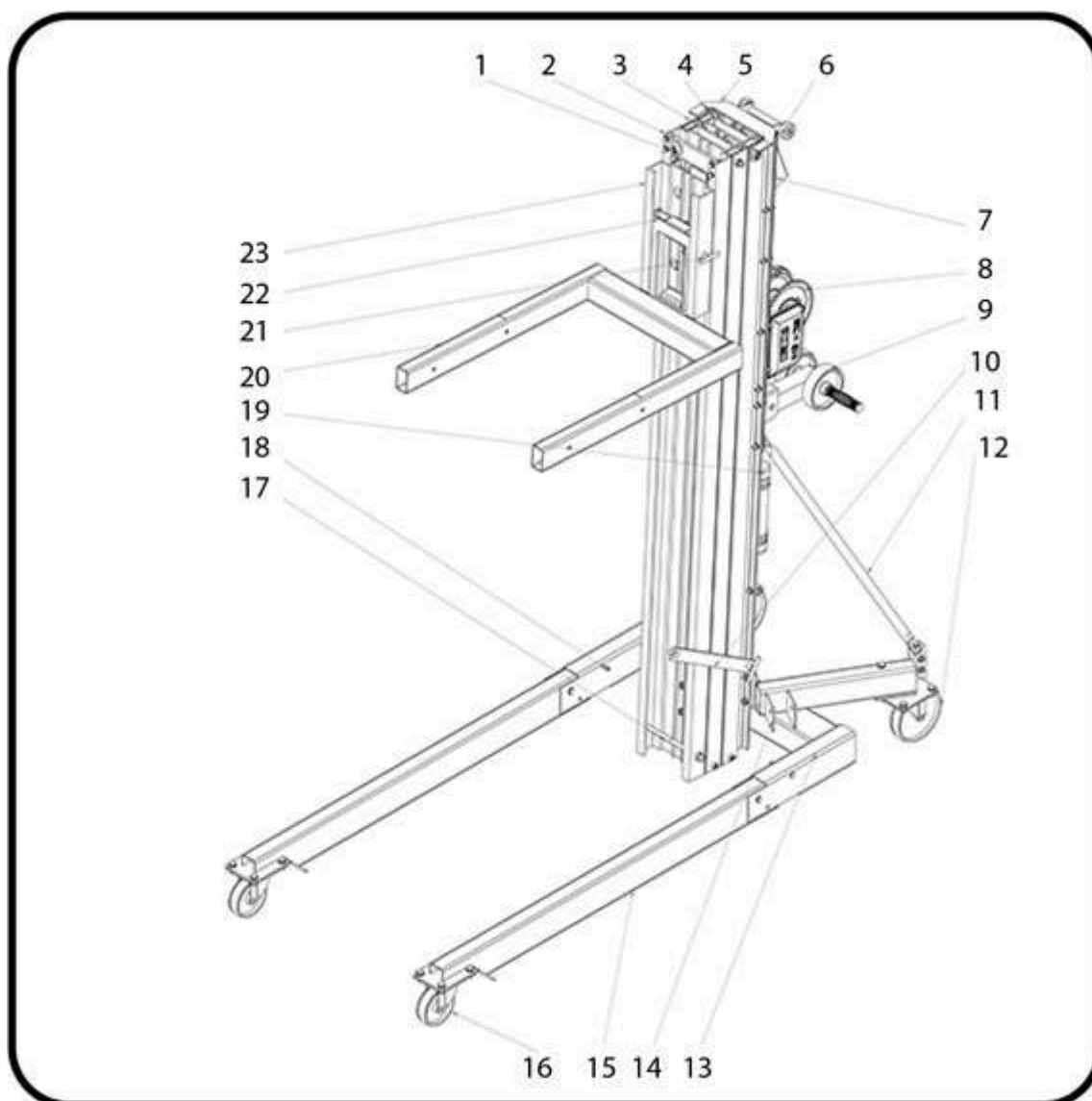

Figure 17.

1	Steel cable	13	Base
2	Final profile	14	Fixation Frontal
3	Itermediate profile	15	stabilizer Frontal
4	Mast	16	wheels Frontal legs
5	Upper reinforcement	17	Wheels
6	Upper side transport wheels	18	fixation
7	Rear plate	19	User manual
8	Winch	20	Frontal fork
9	Central transport wheels	21	Carrier pin
10	Lock for transport	22	Steel plate
11	Reinforcement tight	23	Carrier profile
12	Rear wheels		

HOW TO USE STEP BY STEP

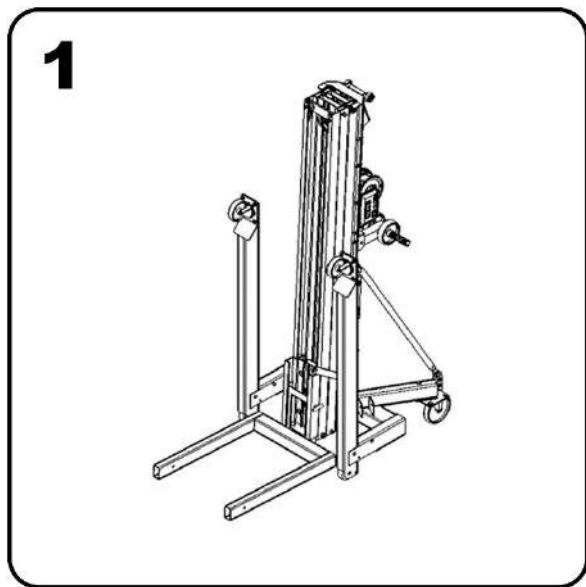

Figure 18

Place the lifter on a flat, stable surface.

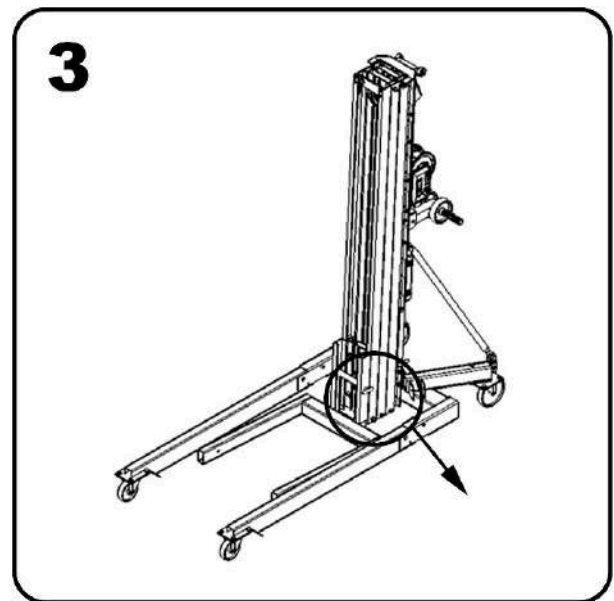

Figure 20

IMPORTANT. Unlock the safety pin on the sections.

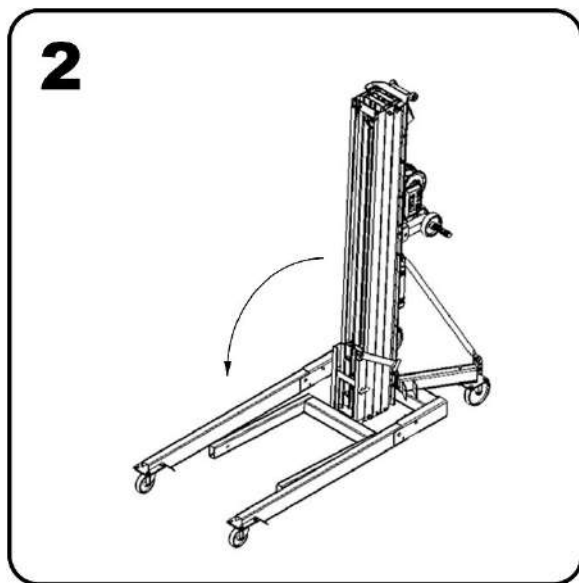

Figure 19

Remove the fixing pins from the stabilizer legs and replace them when fully extended.

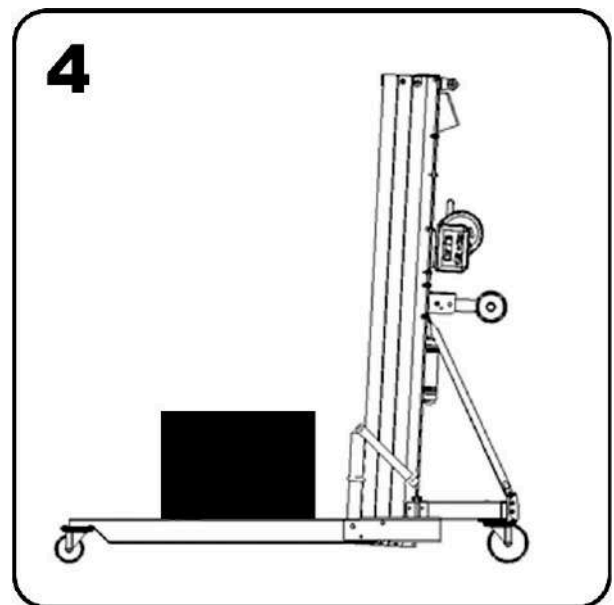

Figure 21

Place the load, taking all the previously mentioned precautions regarding maximum load and securing the load.

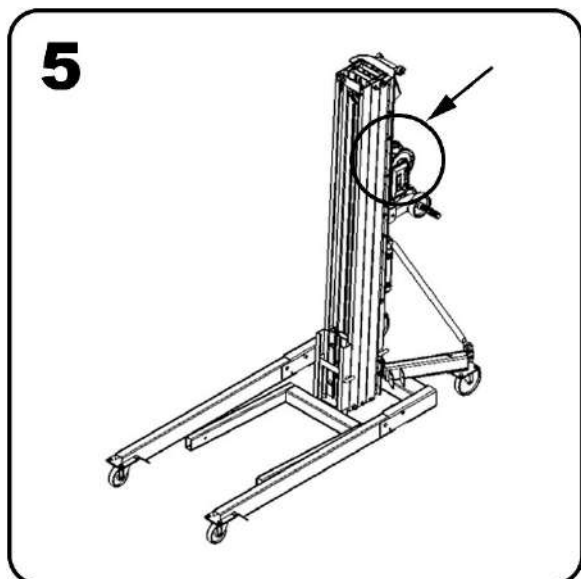

Figure 22

Rotate the winch continuously and evenly, avoiding sudden movements.

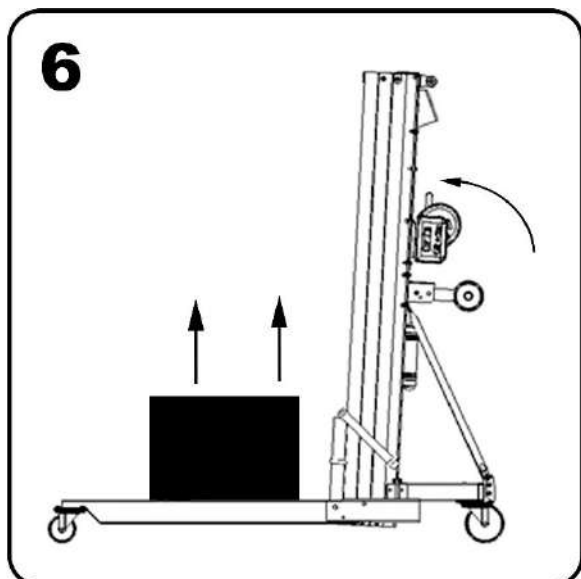

Figure 23

As the winch rotates, the attached load will begin to rise as the different sections are deployed. Ensure at all times that the load does not swing and that there are no obstacles above the load or the lifter during the lifting process.

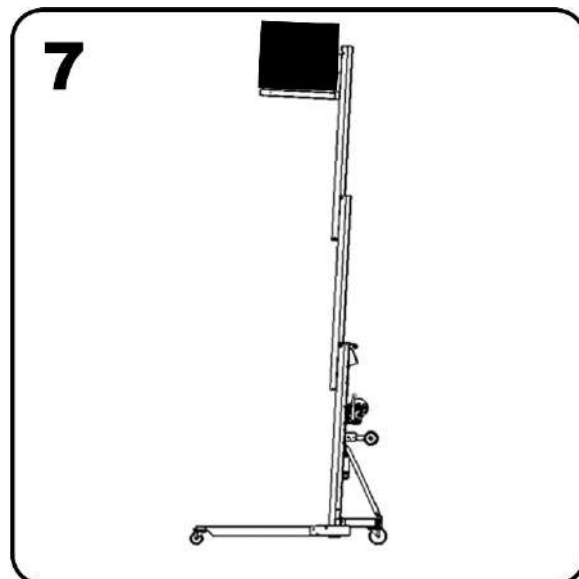

Figure 24

Once the desired height has been reached, stop turning the winch, performing a final check to ensure there are no people or objects under the load.

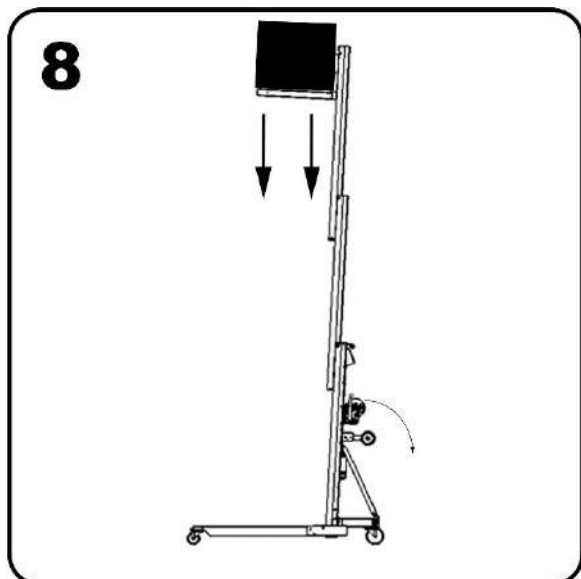

Figure 25

To lower the load, rotate the winch in the opposite direction continuously and evenly, avoiding sudden jerks.

The load will descend slowly, and the profiles will fold throughout the process until they reach their resting position.

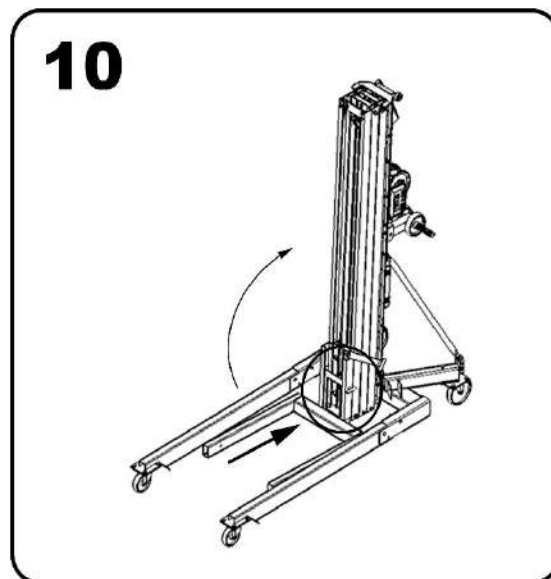

Figure 27

Reattach the sections with the safety pin for transport. Remove the pins securing the front stabilizer legs and fold them to their resting position, as well as the front fork.

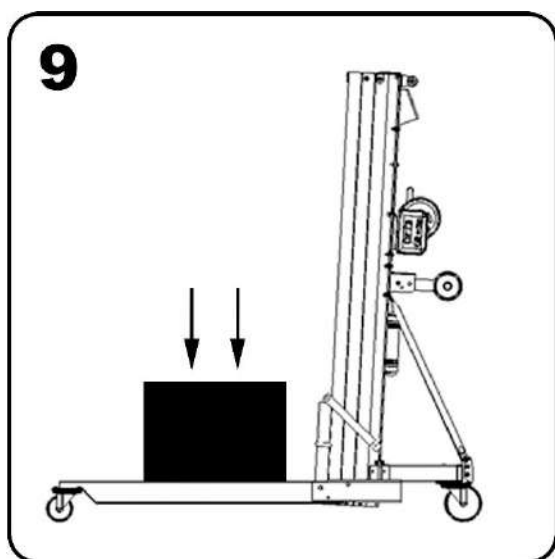

Figure 26

Having reached this resting point with the load in its minimum position, release the load from its fixings and remove it.

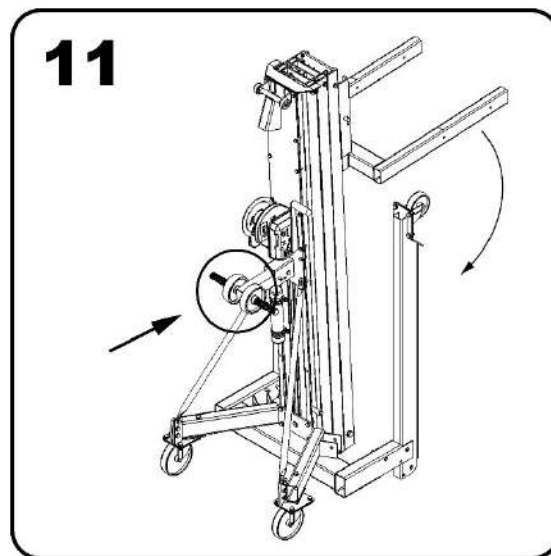

Figure 28

Once all its components are folded, the lifter is ready for transport and storage. You can either use the wheels on the base or fold the lifter horizontally and transport it using the wheels located next to the winch.

ACCESORIES

CT 640 disposesofthe following accessories

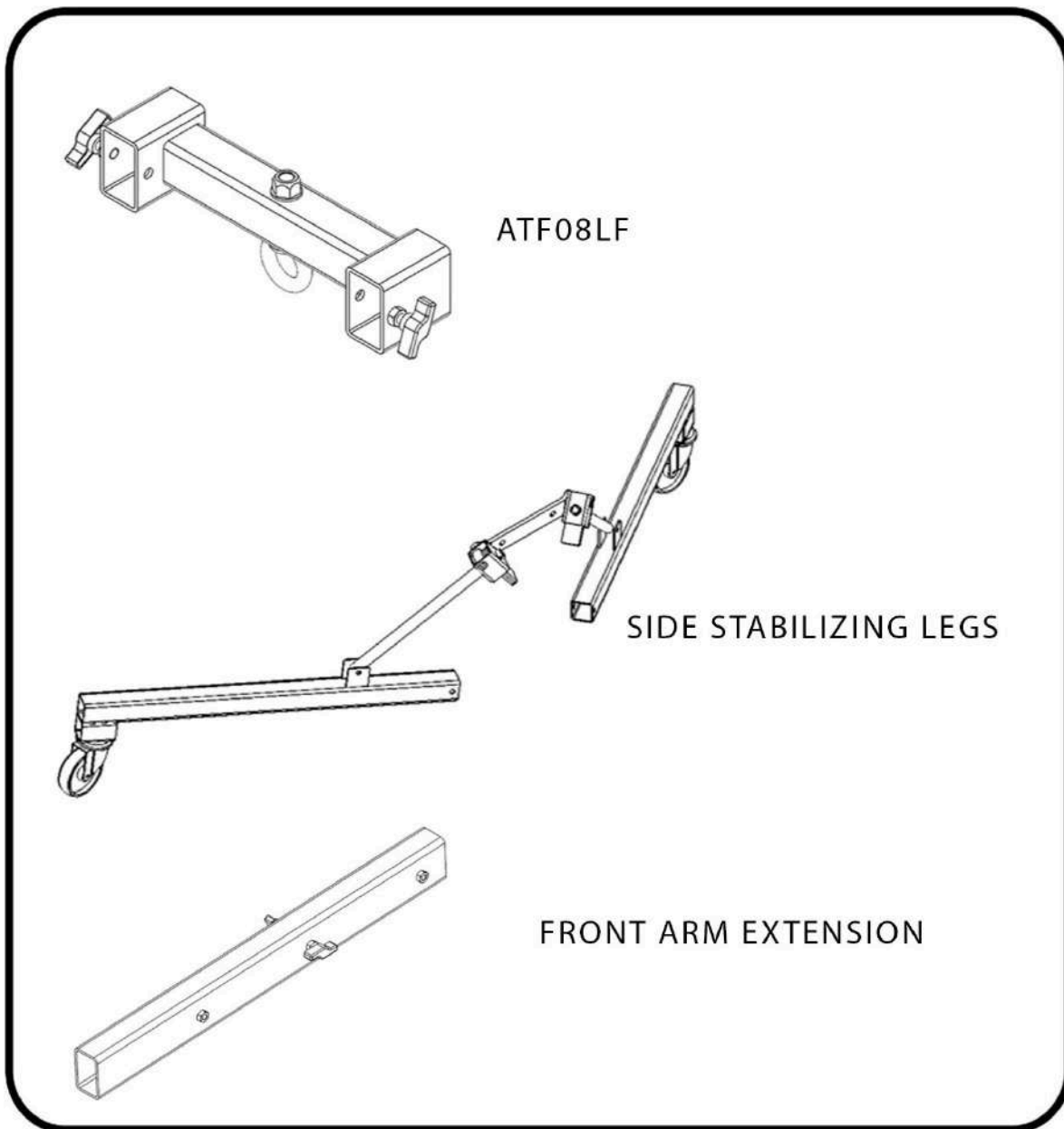

Figure 29

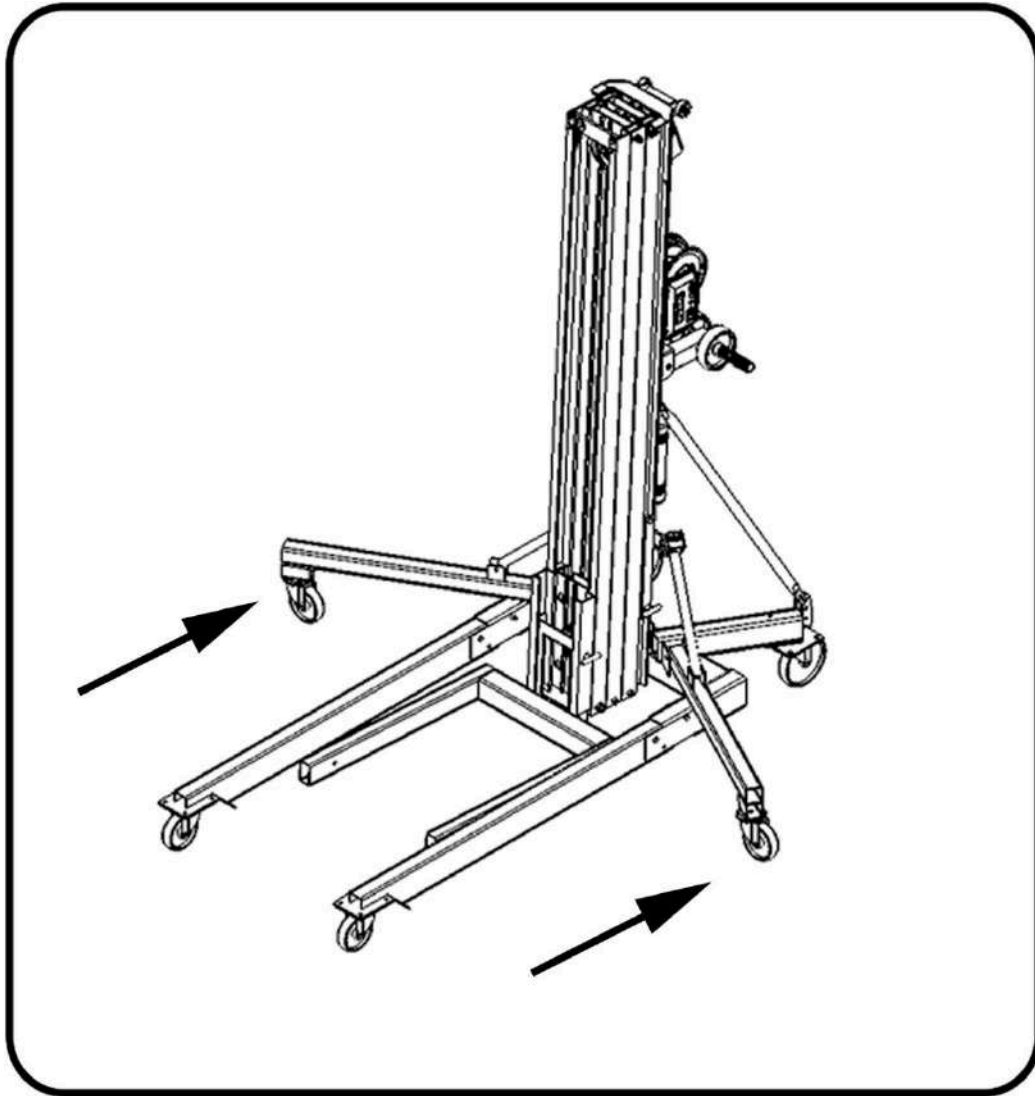

Figure 30

Example of CT 640 lifter with the SIDE STABILIZING LEGS accessory.

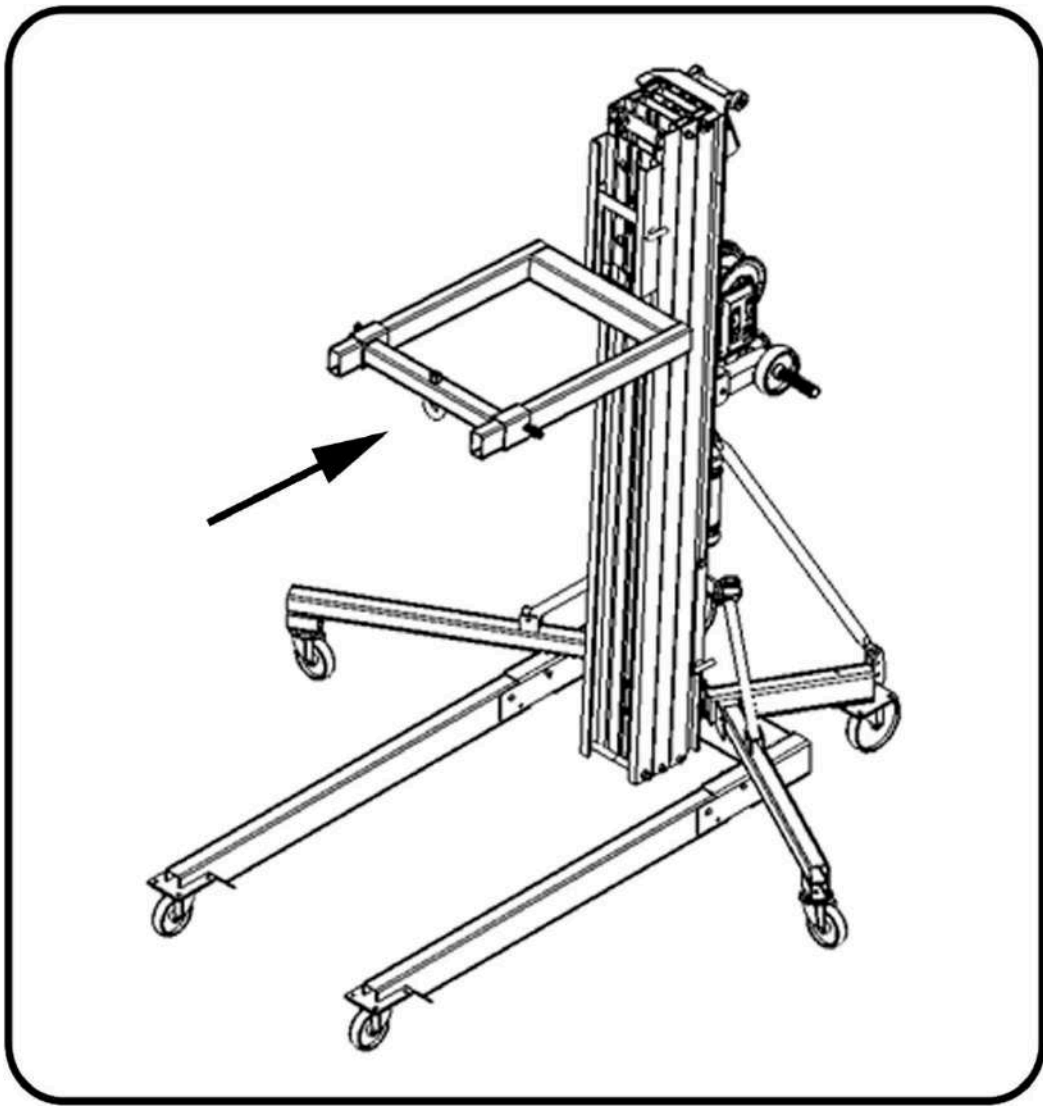

Figure 31
Example of an CT 640 lifter with the ATF08LF accessory

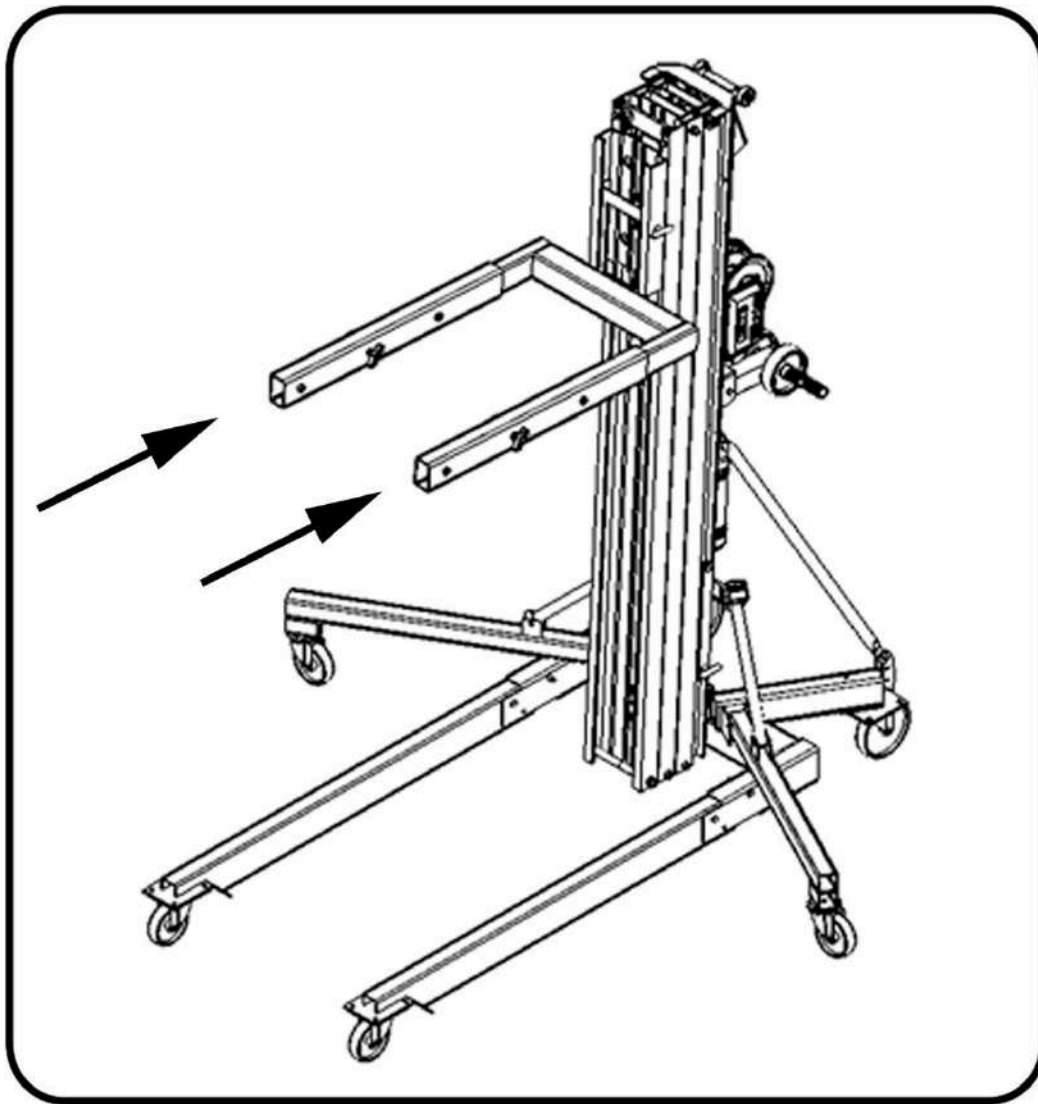

Figure 32

Example of CT 640 lifter with the FRONT ARM EXTENSIONS accessory.

PLACING LOAD

Determine the position where the load will be placed and consult the lifter's capacity according to the attached table. Never exceed it.

The distance to the center of the load is measured from the trolley.

Whenever possible, position the load as close to the trolley as possible. This prolongs the lifter's lifespan.

	DISTANCE FROM THE CENTER OF THE LOAD TO THE NEAREST POINT TO THE CART						
cm	46	51	56	61	66	71	76
inch	18	20	22	24	26	28	30
kg	363	363	363	363	346	329	312
pound	800	800	800	800	763	725	688
cm	81	86	91	97	102	107	
inch	32	34	36	38	40	42	
kg	295	281	268	254	240	227	
pound	650	620	590	560	530	500	

Figure 33

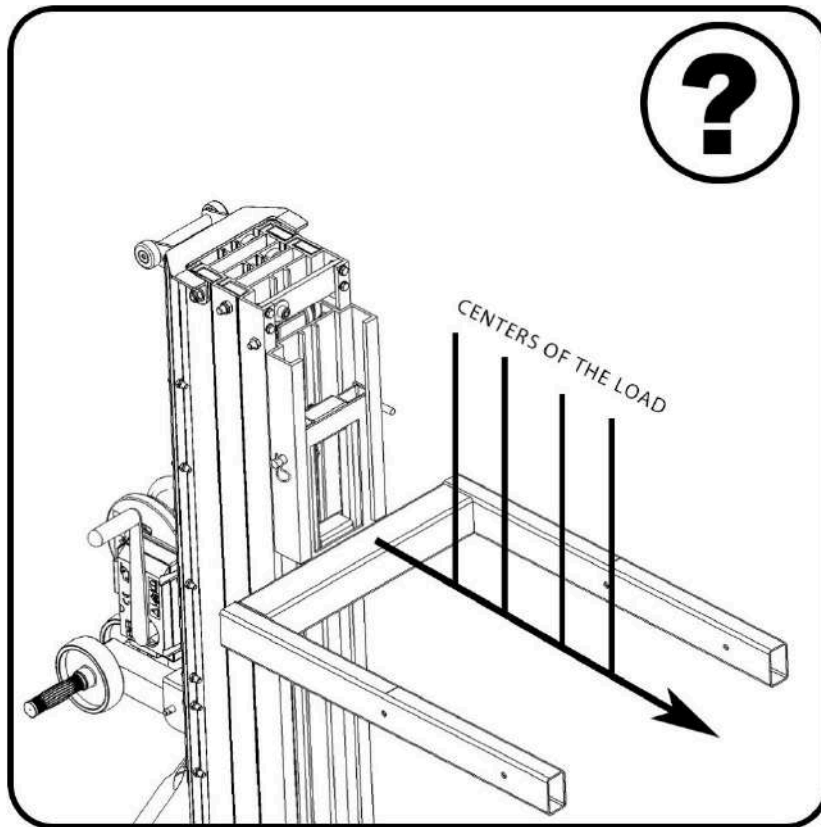

Figure 34

MAINTENANCE

Over time and with use, internal components of computer lifters can deteriorate. Therefore, it is recommended to replace certain parts periodically to ensure optimal lifter performance. A table is included that specifies, as a guide, which parts should be replaced and when.

ITEM	CHANGE	CHANGE
Cable	4 year	6 year
Inner iron pulleys	4 year	6 year
Inner nylon pulleys	4 year	6 year
Inner screws	4 year	6 year

Figure 35



Figure 36

SPECIFICATIONS

Model	CT 640
Folded Height	1990 mm
	6,52 ft
Max. Height	5000 mm
	16,40 ft
Base width	770 mm
	2,52 ft
Folded legs length	1485 mm
	4,87 ft
Unfolded legs length	1930 mm
	6.33 ft
Fork length	745 mm
	29,33 in
Min. Load	25 Kg
	55,12 Lb
Max. Load (*)	363 Kg
	800,2 Lb
Net weight	161 Kg
	354,9 Lb

Figure 37

(*) Check load chart (fig. 33)

DECLARACIÓN DE CONFORMIDAD

Las torres elevadoras descritas cumplen con todos los requerimientos específicos en la directiva 2006/42/EC del Parlamento Europeo y del Consejo de 17 de mayo de 2006 relativo a la Directiva de máquinas.

The lifter lifter described complies with all the specific requirements of Directive 2006/42 / EC of the European Parliament and of the Council of 17 May 2006 on the Machinery Directive.

Fabricante / Manufacturer:	EQUIPSON, S.A.
Persona responsable de recopilar la información técnica <i>Person responsible of the technical data:</i>	Jose Vila Ortiz
Dirección / Address:	Avda. El Saler, 14 46460 – Silla – Valencia (Spain)
Descripción / Description:	Torre de carga frontal /Frontal load lifter

CT 640

CARGA MÁX.: 363 kg



José Vila Ortiz,
Diciembre 2017

DGUV MARK

NUMERODESERIE:	SERIAL NUMBER:	LAUFENDE NUMMER:

Primer test en fábrica	First test in factory.	Erstprüfung im Werk.
Fecha/Date/Datum	Testado por/Tested by/Prüfer	

Examen a los cuatro años.	Four years test	UVV Prüfung (alle 4Jahre)
Fecha/Date/Datum	Testado por/Tested by/Prüfer	

Examen anual a partir del cuarto año.	Annual test after the fourth year.	UVV Jährlicher Test nach dem vierten Jahr.
Fecha/Date/Datum	Testado por/Tested by/Prüfer	

Fecha/Date/Datum	Testado por/Tested by/Prüfer
Fecha/Date/Datum	Testado por/Tested by/Prüfer
Fecha/Date/Datum	Testado por/Tested by/Prüfer
Fecha/Date/Datum	Testado por/Tested by/Prüfer



WORKPRO LIFTERS.
C/Traginers, 4. P.I. - L'Alter,
Alcasser - Valencia SPAIN
Telf +34 961260168
www.worklifters.com