

LUXE TORO 350 RGBAL

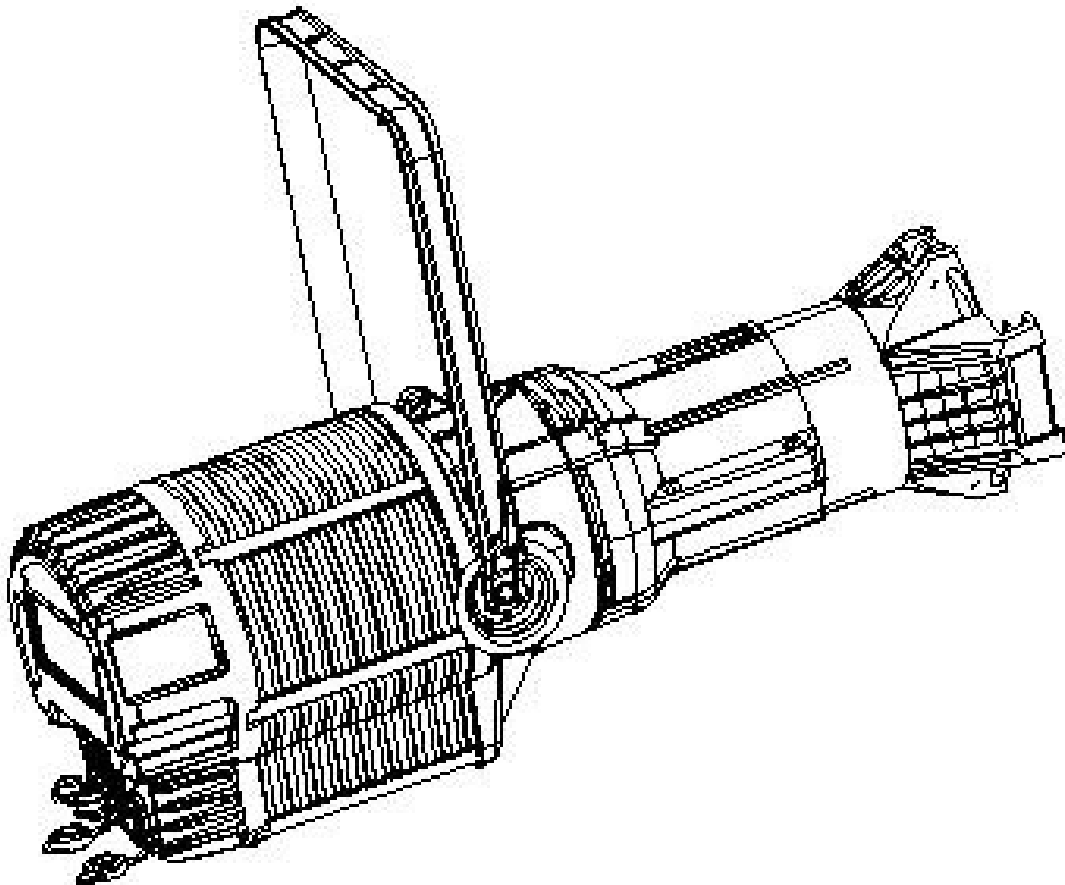

Please read it carefully

Index

1. Before you work .	2
2. Specification.....	3
3. How to set the unit.	4
4. How to control the unit.....	5
5. Troubleshooting	8
6. Fixture Cleaning .	9

1. Before you work



W A R N I N G

Please read the instructions carefully which includes important information about the installation, operation and maintenance.

1.1 Packing instructions :

When you get this product, please take it from carton carefully to make sure whether all the accessories are in and damaged or not. When you find that there are any parts or wrong sign with the carton, or non-operation, please inform us and to keep the carton and shipping bill completely.

1.2AC Power:

Please check the manual before you operate the light. The rating current of the light listed which shows the average current-consume under the normal circumstances.

All the lights must be offered shoot-through circuit, it could not be connected dimmer circuit, although the dimmer channels are completely for 1-100% switch.

Before the light's working, please confirm the correct voltage.

1.3Safety instruction:

Please confirm the same voltage to the light.

Please confirm there is no flammable material around the light.

The light must be set up the ventilating place. The distance is ≥ 51 cm around approach material.

To check the air passage is ok at any time.

The Maximum temperature is $\leq 40^{\circ}\text{C}$ (104°F).

When the lights has problems, please stop to use to contact the supplier. Don't repair it by yourself!

Don't connect by a dimmer.

To confirm the power wire is straight and non-damaged. Don't pull it directly.

Don't look at the bulb when the light is working to avoid any hurt.

Installation:

The light fixture should be bolted to the quick-lock hook. To ensure that the installation is firmly, in order to prevent vibration and slip during operation. Also make sure that the structure attached to the light fixture can support 10 times the weight of it. At the same time, a safety line is used to support 12 times the weight of the light fixture.

The installation of the light fixture should be carried out by professionals, and should be installed in places that are not accessible to people or where no one will casually pass by.

2. Specification

Input voltage	AC100-240V, 50/60HZ
Power consumption	350W
Led source	500W RGBLA COB led
CCT	2500K-8000K
Color rendering	CRI (average): ≥90
Dimming curve	4 kinds
PWM Angle	2-19K
Control mode	36° /19°/26° DMX 512 /RDM
Dmx channel(manual)	6CH /10CH
material	Aluminum die-cast+aluminum alloy
cooling	Silent operation
Power connection	Powercon in/out
Dmx connection	3pin XLR in/out
installation	Clamp or 28mm casing pin(optional)
dimension	673 *301 * 500 m m
N.W	12kg
IP rate	IP20
gobo	optional

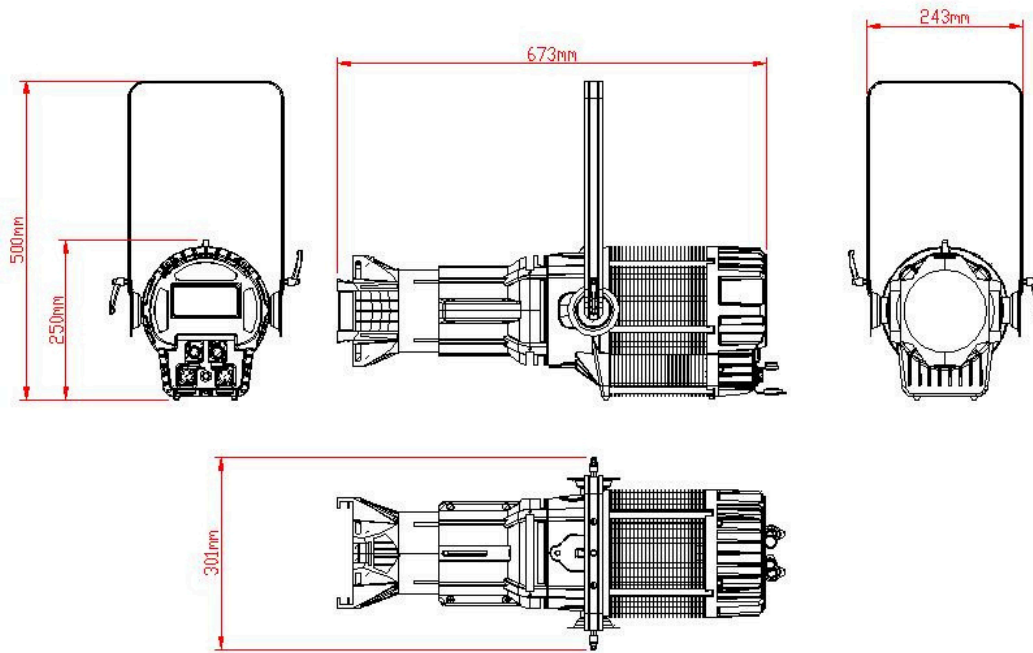

3.How to set the unit

Control menu

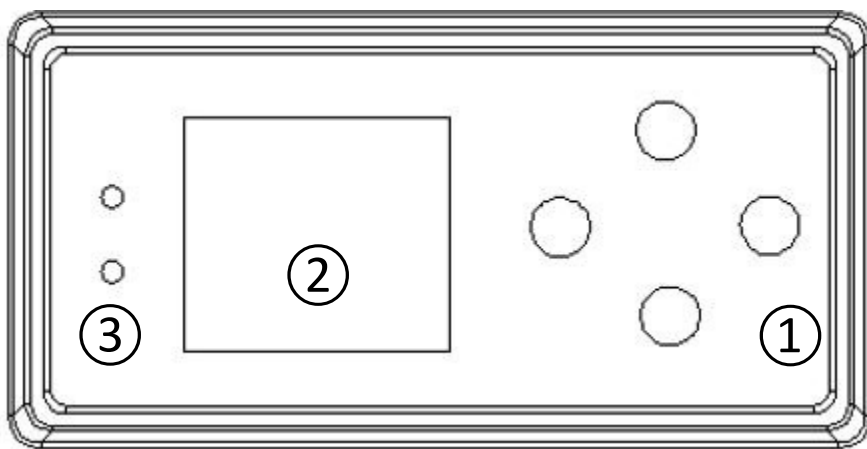

①Button:

MENU	Go to menu selection
DOWN	Go to the next option
UP	Go back to the previous option
ENTER	Confirm the selected function

②Touch screen: LCD 1.77 TFT display various function menus

③LED:

POWER	on	Power indicate
DMX	on	currently DMX signal input

4.How to control the unit

Turn on the light fixture, press the MENU button to enter the MENU mode, when the preset menu is displayed on the display screen, press ENTER to confirm, use the UP and DOWN to select the sub menu, press the ENTER to save the settings or automatically return to the upper menu.

The main functions are as following\$

Main menu	sub menu	Tertiary menu	Default value
CCT	CCT	2500K-	2500K
	dim	-8000K 0-	100%
sRGB	X	-100% X:00-	X:00
	Y	-59 Y:00--59	Y:00
	STA	ST A:00--10 0	ST A:00
	L	L:000--100	L:10 0
root	PIN	----- (UP ↑) (DOWN ↓)	
	R current	020-	200
	G current	-255	220
	B current	020-	220
	L current	-255	250
	A current	020-	250
	temperature	-255	55
	push	020-	No
	power	-255	255
	New PIN	020-	
LE(light effect)	WB(white balance)	R:000-40-	R:12 8
		-255	G:128

Yes/No
0-100
0-255
255

		B:000--255	B:128	
		L:000--255	L:128	
		A:000--255	A:128	
	macro	color	RGBLA	RGBLA
		effect	PJ/GI/PT	PJ
speed		0--100%	50%	
Dim		0--100%	100%	
DMX	add	Add 001	001	
	CH	6CH/10CH	10CH	
setting	SG(signal)	clear	clear	
		keep		
	SS(display)	Yes/No	NO	
	language	中文	English	
		English		
	Bkgrd(display background)	R	065	
		G	105	
		B	230	
	DC(dimming curve)	linear	linear	
		square		
		reversal		
		S line		
	DF(dimming frequency)	2-19K	14K	
		dim mode	stage	stage
			teatre	
	meeting			
FC(fan mode)	controllable	No function		
	long turn			
RES(factory reset)	Factory reset Yes/No	NO		
LOOK	Yes/No	Yes		
Turn(display reverse)	Yes/No	NO		
LOGO	Yes/No	NO		

DMX setting

Select DMX Settings, press the MENU to enter Menu mode, and press UP or DOWN to select: DMX Address or Channel mode. Press ENTER to save.

DMX address

Select the DMX address and press the MENU button to enter. Press UP or down to adjust the DMX address (1~512). Once the desired DMX address is selected, press the ENTER to save.

Channel mode

Select Channel mode and press the MENU button to enter. select: 6CH/10CH then press ENTER to save.

Dimming curve

Select the dimming curve and press the MENU to enter. Press UP or DOWN to select: linear, square, inverse square, or S-curve.

Curve details check below:

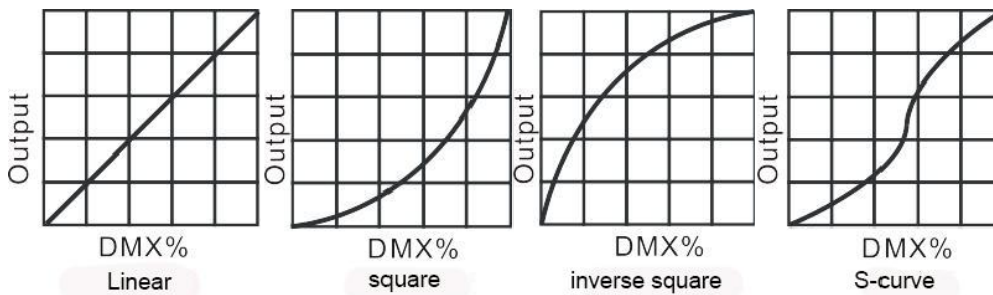

Mode 1 (linear) : With the increase of DMX value, the increase of light intensity tends to be linear:

Mode 2 (square rate) : The lines are finer when the light intensity is controlled at a low value. The line is thicker when the value is high:

Mode 3 (inverse square rate) : The lines are thicker when the light intensity is controlled at a low value. In the high value of the line is thinner:

Mode 4 (S-curve) : The light intensity is controlled at low and high values with fine lines, and at intermediate values with thick lines.

DMX address setting

When using a universal DMX controller to control a light fixture, you need to set the starting address (1-512) for the light so that the light can receive the DMX signal.

Press the MENU enter MENU mode, select DMX settings, press ENTER to confirm, select DMX address, press ENTER to confirm, the current address will be displayed on the display screen, and then

use the UP or DOWN to select the address code (1-512), press ENTER to save.

Please refer to the chart below to set the address of the first 4 fixtures:

Chan nel mode	fixture 1 DMX address	fixture 2 DMX address	fixture 3 DMX address	fixture 4 DMX address
6CH	1	7	13	19
10CH	1	11	21	31

DMX512 channel:

6CH:

Chann el	unction	description
1	R	RDim Fromdarktobright
2	G	GDim Fromdarktobright
3	B	BDim Fromdarktobright
4	L	LDim Fromdarktobright
5	A	ADim Fromdarktobright
6	CCT	2500K-8000K

10CH

Chann el	unction	description
1	Dim all	From dark to bright
2	Strobe all	From slow to fast
3	Function selection	0-5 empty 6-100 jump 101-150 gradient 151-200 pulsation 201-255 sound active
4	Function speed	Function speed
5	CCT	2500K--8000K

6	R	RDim Fromdarktobright
7	G	GDim Fromdarktobright
8	B	BDim Fromdarktobright
9	L	LDim Fromdarktobright
10	A	ADim Fromdarktobright

5.Troubleshooting:

Following are a few common problems that may occur during operation. Here are some suggestions for easy troubleshooting:

- The fixture does not work, no light
1. Check the connection of power and main fuse.
 2. Measure the mains voltage on the main connector.
 - Not responding to DMX controller
 1. DMX LED should be on. If not, check DMX connectors, cables to see if link properly.
 2. If the DMX LED is on and no response to the channel, check the address settings and DMX polarity.
 3. If you have intermittent DMX signal problems, check the pins on connectors or on PCB of the fixture or the previous one.
 4. Try to use another DMX controller.
 5. Check if the DMX cables run near or run alongside high voltage cables that may cause damage or interference to DMX interface circuit.
 - Channel is faulty
 1. The stepper motor or motor lead may be damaged.
 2. The drive circuit of the motor may be damaged

6.Fixture cleaning:

The cleaning of internal must be carried out periodically to optimize light output. Cleaning frequency depends on the environment in which the fixture operates: damp, smoky or particularly dirty surrounding can cause greater accumulation of dirt on the fixture's optics.

- Clean with soft cloth using normal glass cleaning fluid.
- Always dry the parts carefully.
- Clean the external optics at least every 20 days. Clean the internal optics at least every 20 days.

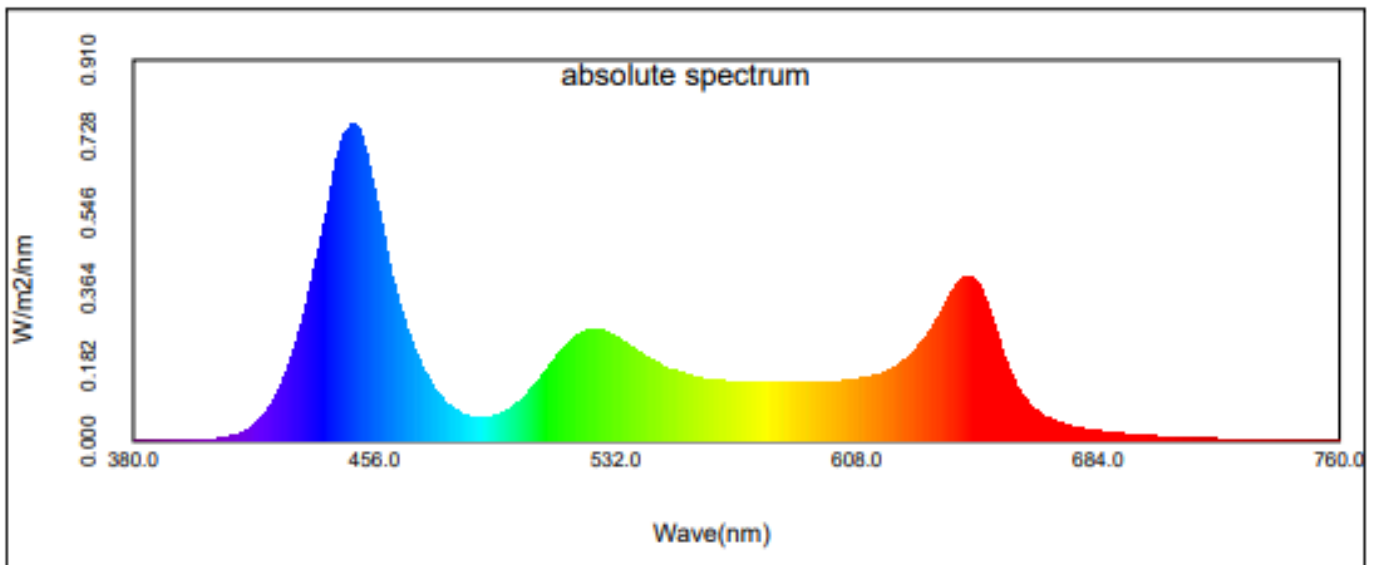

Items	value	Items	value	Items	value
Illuminance E(lx)	13097.5	E(fc)	1217.24	Irradiance Ee(W/m²)	5.7027E1
Ee(W/m²)(500~600nm)	1.754E1	S/P	2.716	x	0.2840
y	0.2425	u'	0.2127	v'	0.4085
CCT(K)	14869	Duv	-0.02881	Lp(nm)	449.0
Ld(nm)	446.0	HW(nm)	26.0	Purity(%)	28.5
R ratio(%)	19.2	G ratio(%)	74.5	B ratio(%)	6.3
SDCM	55.7	Ra	63.2	R1	58.4
R2	85.8	R3	52.7	R4	51.4
R5	69.7	R6	82.0	R7	72.8
R8	32.8	R9	-93.8	R10	78.1
R11	43.6	R12	66.3	R13	65.6
R14	70.0	R15	40.0	IP	42917.5
Integrating time	0.2	CQS	75.27	GAI EES	134.9
GAI BB 8	122.8	GAI BB 15	125.7	Rf	69
Rq	120	E(e,sc)(W/m²)	1.9746E1	E(e,mc)(W/m²)	1.8975E1
E(e,lc)(W/m²)	2.1604E1	E(e,rh)(W/m²)	2.0927E1	E(e,mel)(W/m²)	1.9862E1
K(v,sc)(W/lm)	1.5076E-3	K(v,mc)(W/lm)	1.4487E-3	K(v,lc)(W/lm)	1.6495E-3
K(v,rh)(W/lm)	1.5978E-3	K(v,mel)(W/lm)	1.5165E-3	E(v,sc) D65(lx)	2.4160E4
E(v,mc) D65(lx)	1.3034E4	E(v,lc) D65(lx)	1.3263E4	E(v,rh) D65(lx)	1.4436E4
E(v,mel) D65(lx)	1.4976E4	r(v,sc) D65	1.8446E0	r(v,mc) D65	9.9514E-1

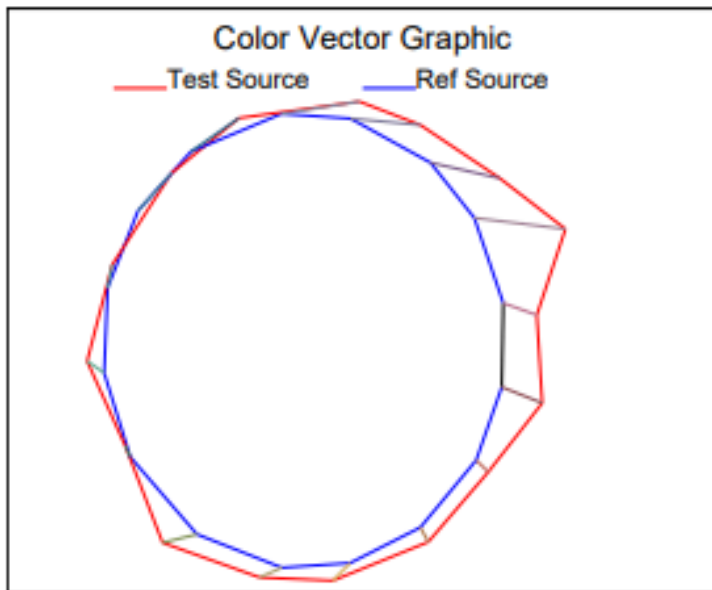
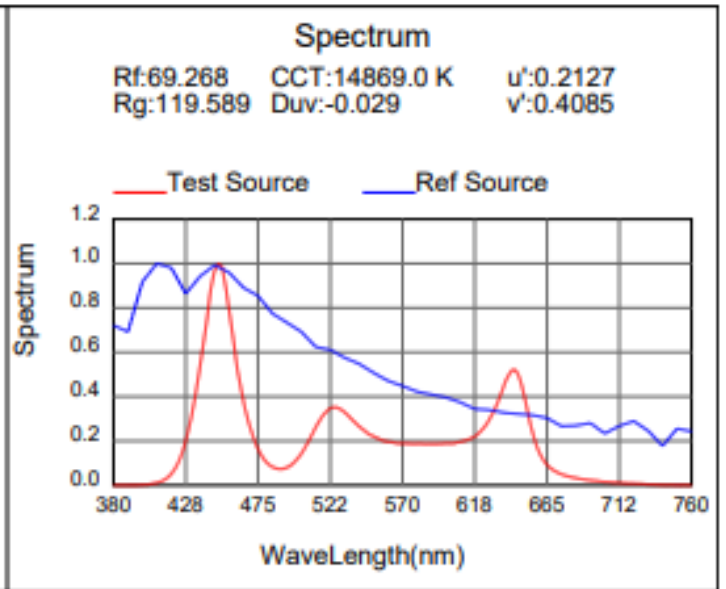
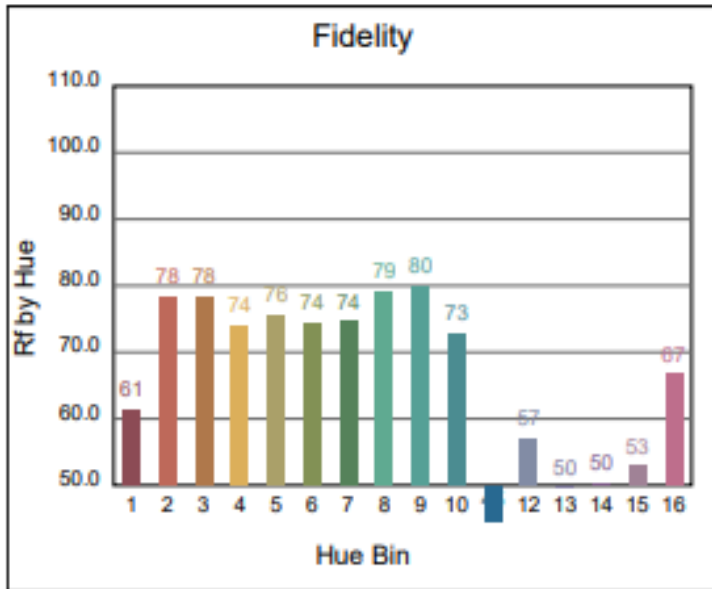
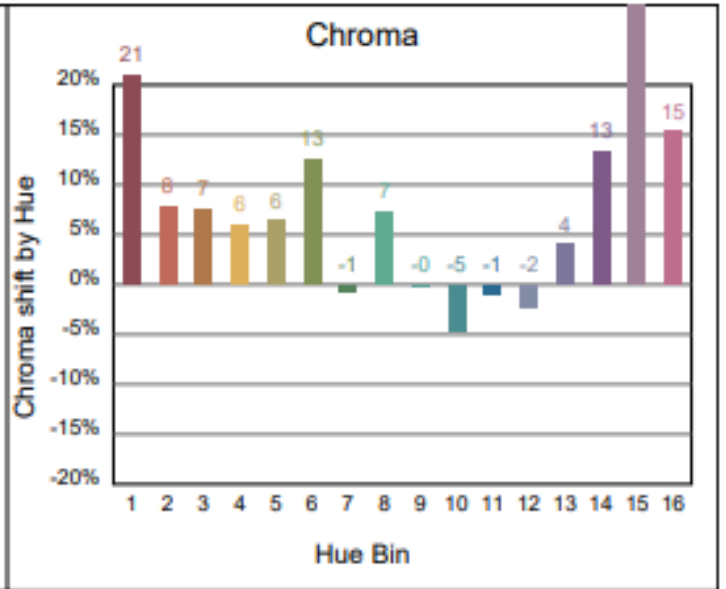
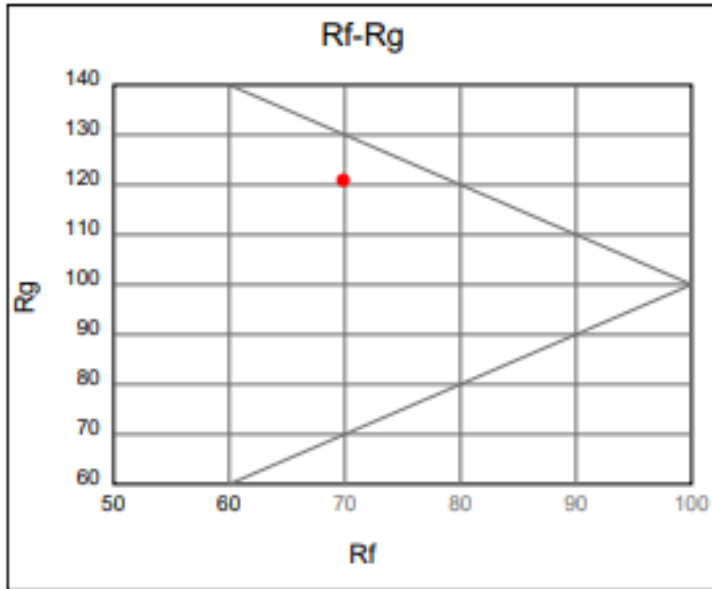

Data

			Graphic shift(%)	
Hue Bin	Hue Angle	Rf	Chroma	Hue
1	0.0° - 22.5°	61	21	3
2	22.5° - 45.0°	78	8	1
3	45.0° - 67.5°	78	7	0
4	67.5° - 90.0°	74	6	10
5	90.0° - 112.5°	76	6	10
6	112.5° - 135.0°	74	13	12
7	135.0° - 157.5°	74	-1	5
8	157.5° - 180.0°	79	7	7
9	180.0° - 202.5°	80	-0	10
10	202.5° - 225.0°	73	-5	23
11	225.0° - 247.5°	45	-1	28
12	247.5° - 270.0°	57	-2	39
13	270.0° - 292.5°	50	4	34
14	292.5° - 315.0°	50	13	32
15	315.0° - 337.5°	53	35	29
16	337.5° - 360.0°	67	15	8

Suggest table

Sector	Lightness	Chroma	Hue
R	-5	-3	-1
R/Y	-1	-2	-1
Y	-2	-2	-2
Y/G	-1	-3	-2
G	-1	-4	-1
G/C	1	-3	2
C	2	-2	0
C/B	2	-1	-2
B	0	-4	-3
B/M	1	-3	-1
M	-1	-2	-2
M/R	-4	-3	-2

Color

