

Torrent Spot IP

450w IP65 LED Spot/Beam Moving Light

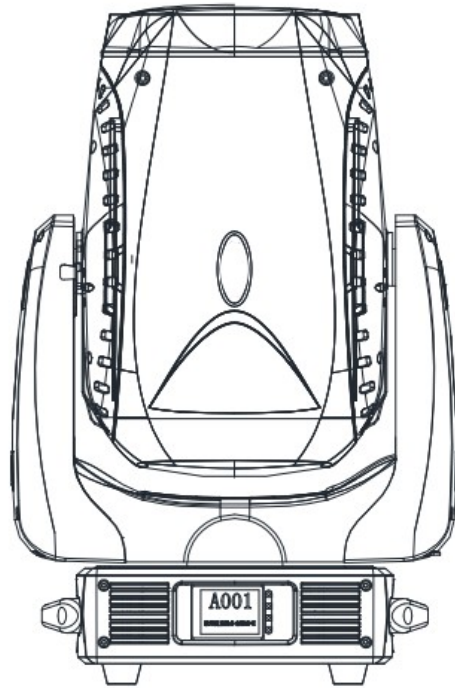

User Manual



Table of Contents

- 1. Introduction and Setup.....3
 - Unpacking and In the Box.....3
 - Mounting and Operation.....3
 - Features.....3
 - Safety Precautions.....7
 - Customer Support.....8
- 2. Setup and Operation.....9
 - Using the LCD Menu and Buttons.....9
 - DMX Setup.....10
 - DMX Basics.....10
 - DMX Wiring.....10
 - DMX Modes and Configuration.....12
- 3. Maintenance.....16
 - Routine Maintenance.....16
 - Troubleshooting Problems.....16
 - A. The unit does not work:.....16
 - B. Not Responding to the DMX Controller.....16
- 4. Technical Specifications.....17
- 5. Photometrics.....18

1. Introduction and Setup

Unpacking and In the Box

Thank you for choosing our Torrent Spot IP. For your own safety, please read this manual before installing or using the device. This manual covers the important information on installation and applications. Please install and operate the fixture with following instructions. Meanwhile, please keep this manual for future needs.

In the box you will find:

- Torrent Spot IP Fixture 1
- Integrated Power and Signal Cables 1
- Swivel-Clamps 2

Mounting and Operation

Clamp Mounting: The Torrent Spot IP provides a unique mounting bracket assembly with integrated clamps in the base of the fixture. The clamps fold flat for table-top operation.

As an added safety measure be sure to attached at least one properly rated safety cable to the fixture using on of the handles.

Features

- 450w IP65 LED Spot/Beam Moving Head
- Variable Speed Strobe – 0.5hz-25hz
- Motorized Zoom – 1.3° to 23°
- 540 Degree Pan, 245 Degree Tilt, 16 Bit Control
- Color Wheel – 10 Colors + Open White
- 2 Gobo Wheels – 9 Fixed Gobos and 8 Rotating and Replaceable Gobos
- Prism – 8 Facet Rotating and Indexable Prism
- Motorized Frost Filter
- Motorized Focus
- Variable-Speed Temperature-Controlled Fan Cooling

Color Wheel:

The Torrent Spot IP features 10 colors + Open White:



Colors as shown are representative samples for fixture profiles, but should not be taken as "exact color". Refer to sample videos for exact color.

Gobo Wheel:

The Torrent Beam Features 2 Gobo Wheels.

First is the fixed gobo wheel, which features 9 gobos:

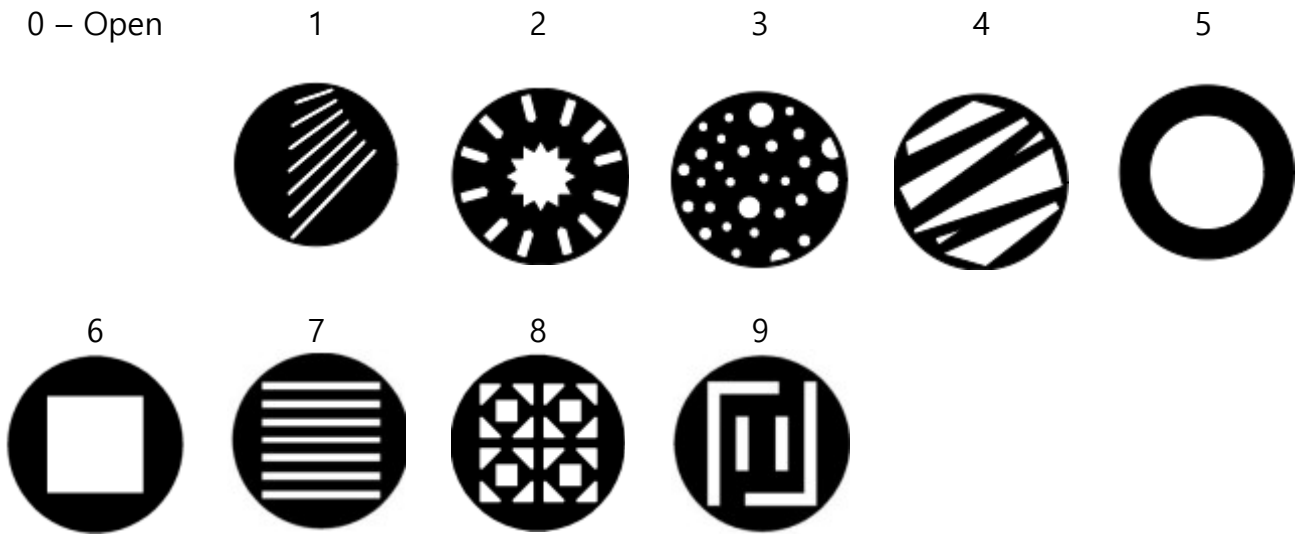

Second is the rotating gobo wheel, which features 8 interchangeable gobos.

Gobo Sizing is as follows:

Metal Patterns are OD 15.5mm, ID 12mm

Glass Patterns are OD 15.5mm, ID 11mm

The first 4 gobos are glass, the second 4 are metal:

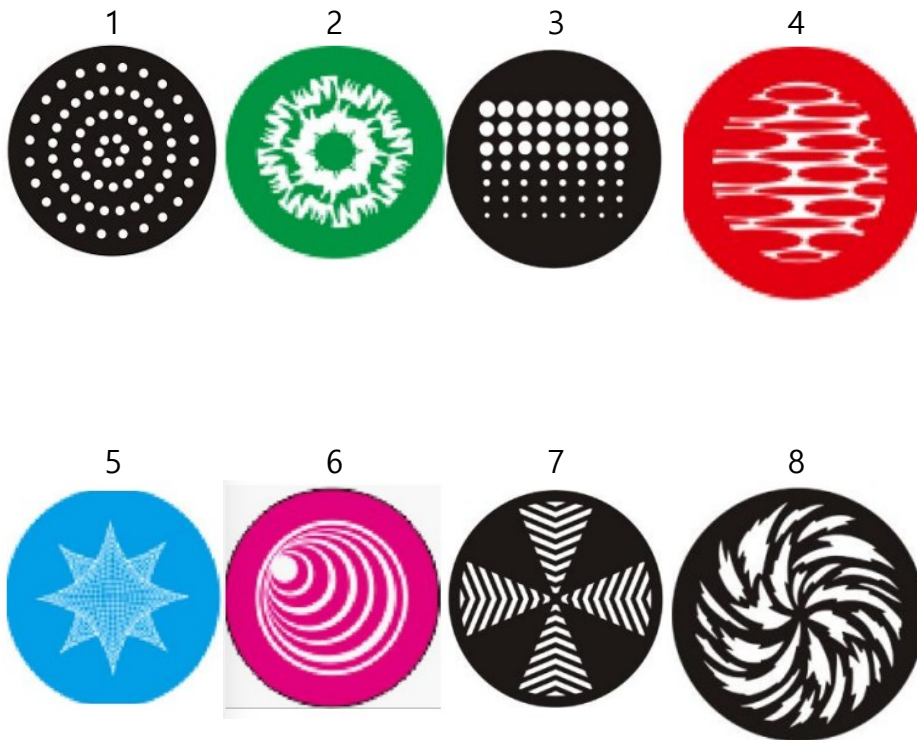

Safety Precautions

Please keep this User Guide for future consultation. If you sell the unit to another user, be sure that they also receive this instruction manual.

Caution: For added protection mount the fixtures in areas outside walking paths, seating areas, or in areas where the fixture might be reached by unauthorized personnel.

Before mounting the fixture to any surface, make sure that the installation area can hold a minimum point load of 10 times the device's weight.

Fixture installation must always be secured with a secondary safety attachment, such as an appropriate safety cable.

Never stand directly below the device when mounting, removing, or servicing the fixture.

From a ceiling, or set on a flat level surface (see illustration below). Be sure this fixture is kept at least 0.5m (1.5ft) away from any flammable materials (decoration etc.).

Always use and install the supplied safety cable as a safety measure to prevent accidental damage and/or injury in the event the clamp fails.

DO NOT connect the device to any dimmer pack.

During initial start-up some smoke or smell may arise. This is a normal process and does not necessarily mean that the device is defective, and it will decrease gradually within 15 minutes.

Don't try to modify the fixture without any instruction by the manufacturer.

Warranty is voided if there are any malfunctions from not following the user manual while operating or any hazardous operation, like shock short circuit, electronic shock, lamp broken, etc.

Customer Support

WARRANTY POLICY

GAMMA LED Vision warrants its products for the periods set below from the date of purchase to be free of manufacturer and workmanship defects. Warranty does not cover normal wear and tear caused by force, negligence or misuse of products. GAMMA LED Vision is not responsible for any damages or injury caused by misuse or improper handling of the products and in accordance with instructions and specifications of manual.

Warranty terms are as follows:

LED Fixtures:

Indoor: 2 Years

Outdoor (IP 54 or higher): 1 Year

Lamp Fixtures: 1 year / excludes the lamp

LED Video Products:

Indoor: 2 Years

Outdoor (IP 54 or higher): 1 Year

Controllers: 2 years

Batteries: 6 months

All Trussing Related Products and Accessories: 1 Year

Please visit WWW.GAMMALEDVISION.COM for complete Limited Warranty terms and contact information.

2. Setup and Operation

Using the LCD Menu and Buttons

Turn on the light, press the **MENU** button to enter the menu mode, use the **UP** and **DOWN** buttons to find the menu item, and **ENTER** to enter the menu.

When the preset menu is displayed on the display screen, press the **ENTER** button to confirm, use the **UP** and **DOWN** buttons to select the sub menu, press the **ENTER** button to save the settings or automatically return to the previous menu.

Press the **MENU** button to return, or wait for one minute and then exit the menu mode automatically. **Menu Operation:**

MENU	Address	DMX Address	Set DMX Address, 1-512
	Work Mode	DMX Mode	Set the signal mode, the only option is DMX mode for this fixture.
	CH Mode	Set the DMX Channel Mode	24 CH – Default mode
			21 CH – Mode2
	Test Mode	Sets the unit in TEST mode – allowing you to manually scroll and set values for each parameter of the light.	
	XY Setup	Allows you to invert and modify the pan and tilt.	X Invert: Inverts the pan of the light.
			Y Invert: Inverts the tilt of the light.
			XY Speed: Can be used to slow down the speed of the light. Default is "High".
	Signal	Allows you to see a readout of the DMX values being received.	
	System	Allows you to change system-wide settings.	Backlight Time
Screen Direction			
Language – English or Chinese – CHANGE WITH CAUTION!			
Reset	Does a re-homing of the unit.		

DMX Setup

DMX Basics

DMX512 stands for digital multiplex 512. This means that 512 channels are controlled digitally through 1 data cable.

A channel is a set of 255 steps that are assigned to control attributes in each light. This may be a color like red, green or blue, and intensity, strobe, pan/tilt or other attributes.

Multiple sets of 512 "universes" may be used. Only 1 universe will travel on a DMX cable, but through networked DMX (Art-Net or sACN E1.31), many universes can travel over a network.

DMX Wiring

DMX works by connecting 1 or multiple lights to the output of a DMX lighting console or software with a DMX interface.

DMX lights connect in what is called a "daisy-chain". Your first DMX cable will plug its male DMX connector into the female DMX connector on your lighting console. The remaining female connector will then connect to the DMX input on your first light.

You may then connect your next fixture to the output of your first light, and continue the chain.

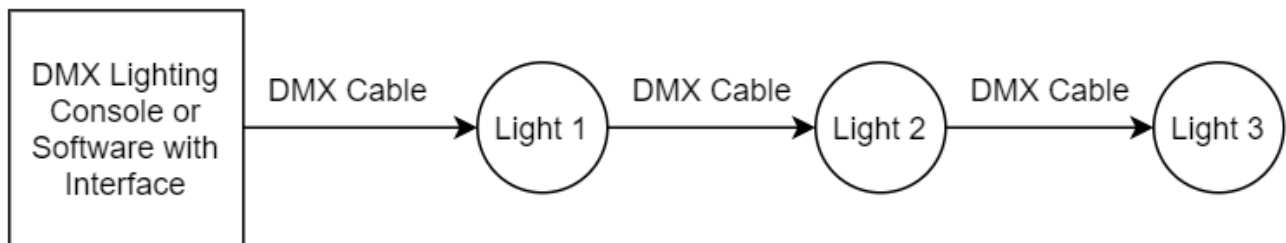

32 Fixture Rule – DMX only allows you to connect up to 32 fixtures in a single daisy chain for signal strength. Sometimes, depending on the fixtures and cable length, this number is less (or more).

DMX Cables can be 3-pin or 5-pin. These use the same type of data, and in the 5-pin only pins 1, 2, and 3 are used. The cable should be a 2 conductor, shielded cable of at least 110 ohms resistance. Microphone cable is not DMX cable.

Please refer to the diagram below:

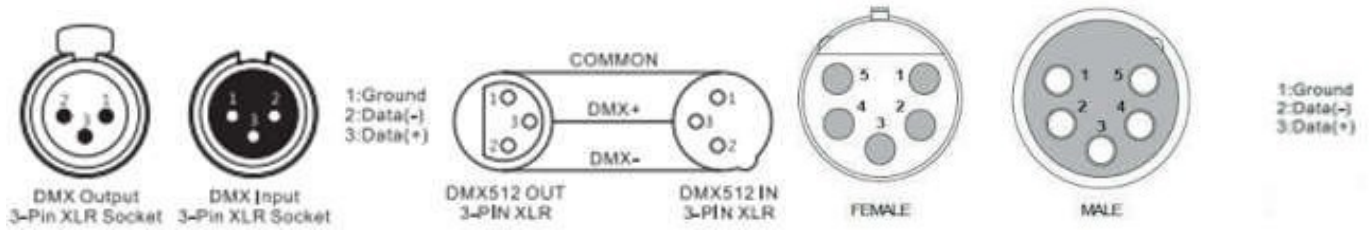

For installations where the DMX cable has to run a long distance or is in an electrically noisy environment, it is recommended to use a DMX terminator. This helps in preventing corruption of the digital control signal by electrical noise and reflections. The DMX terminator is simply an XLR plug with a 120 Ω resistor connected between pins 2 and 3, which is then plugged into the output XLR socket of the last fixture in the chain. Please see illustrations below:

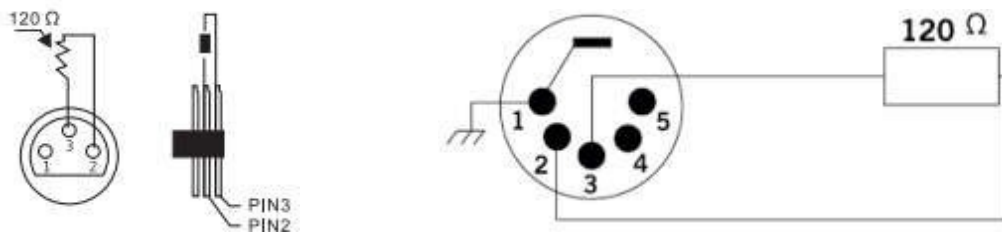

DMX Modes and Configuration

The Torrent Spot IP has multiple DMX modes, sometimes called "personalities", "profiles", or as we will use here "modes".

In general, modes with more DMX channels offer a greater level of control or options but take up more of your output channels on your lighting console or software.

Modes with less DMX channels often offer less control, but may be plenty for your needs. *Depending on your needs and control solution, you may not need channels for automated programs, strobes, or macros – your console may have great effects! In this case, you can use a lesser channel mode and fit more lights per DMX universe.*

View the DMX mode charts below to find the mode that best suits your needs.

DMX Channel Mode Sheet:

On the left side of the sheet you will see the different modes and which channel corresponds to each function listed on the right in the given mode.

24CH Mode1	21CH Mode2	Function	Channel Value	Description
1	1	Dimmer	0-255	Intensity, Low to High
2		Dimmer Fine	0-255	Fine Control of Intensity
3	2	Strobe	0-8	Open
			9-64	Variable Speed Strobe, Slow to Fast
			65-195	Open
			196-250	Random Strobe, Slow to Fast
			251-255	Open
4	3	Color Wheel	0-5	Open
			6-12	Open/Red
			13-19	Red
			20-26	Red/Yellow
			27-33	Yellow
			34-40	Yellow//Light Blue
			41-47	Light Blue
			48-54	Light Blue/Green

			55-61	Green
			62-68	Green/Magenta
			69-76	Magenta
			77-83	Magenta/Amber
			84-90	Amber
			91-97	Amber/Light Green
			98-104	Light Green
			105-111	Light Green/CTO
			112-118	CTO
			119-127	CTO/Violet
			128-134	Violet
			135-141	Voilet/Deep Blue
			142-148	Deep Blue
			149-155	Deep Blue/Open
			156-205	CW Color Scroll, Slow to Fast
			206-255	CCW Color Scroll, Fast to Slow
5	4	N/A		
6	5	N/A		
7	6	N/A		
8	7	N/A		
9	7	Gobo Wheel	0-3	Open
			4-7	Gobo 1
			8-11	Gobo 2
			12-15	Gobo 3
			16-19	Gobo 4
			20-23	Gobo 5
			24-27	Gobo 6
			28-31	Gobo 7
			32-35	Gobo 8
			36-39	Gobo 9

			40-76	CW Gobo Scroll, Slow to Fast
			77-84	Open/Stop Rotation
			85-121	CCW Gobo Scroll, Slow to Fast
			122-137	Gobo 1 Shake, Slow to Fast
			138-153	Gobo 2 Shake, Slow to Fast
			154-169	Gobo 3 Shake, Slow to Fast
			170-185	Gobo 4 Shake, Slow to Fast
			186-201	Gobo 5 Shake, Slow to Fast
			202-217	Gobo 6 Shake, Slow to Fast
			218-223	Gobo 7 Shake, Slow to Fast
			224-239	Gobo 8 Shake, Slow to Fast
			240-255	Gobo 9 Shake, Slow to Fast
10	8	Rotating Gobo Wheel	0-2	Open
			3-5	Rotating Gobo 1
			6-10	Rotating Gobo 2
			11-16	Rotating Gobo 3
			17-22	Rotating Gobo 4
			23-28	Rotating Gobo 5
			29-34	Rotating Gobo 6
			35-40	Rotating Gobo 7
			41-52	Rotating Gobo 8
			53-70	Gobo 1 Shake, Slow-Fast
			71-88	Gobo 2 Shake, Slow-Fast
			89-106	Gobo 3 Shake, Slow-Fast
			107-124	Gobo 4 Shake, Slow-Fast
			125-142	Gobo 5 Shake, Slow-Fast
			143-160	Gobo 6 Shake, Slow-Fast
			161-178	Gobo 7 Shake, Slow-Fast
			179-196	Gobo 8 Shake, Slow-Fast
			197-226	CW Gobo Scroll, Slow to Fast

			227-255	CCW Rotation, Slow to Fast
11	9	Gobo Rotation	0-127	Gobo Indexing
			128-191	CW Rotation, Slow to Fast
			129-255	CCW Rotation, Fast to Slow
12		Gobo Rotation Fine	0-255	Fine Control of Gobo Rotation
13	10	Frost	0-127	Open
			128-255	Frost Inserted
14	11	Prism	0-127	Open
			127-255	Prism Inserted
15	12	Prism Rotate	0-127	Index Prism
			128-190	Prism Rotate CW, Fast to Slow
			191-194	Stop
			195-255	Prism Rotate CCW, Slow to Fast
16	13	Focus	0-255	Focus Control
17	14	Zoom	0-255	Zoom Control, 1.3° to 23°
18	15	Pan	0-255	Pan Control
19	16	Pan Fine	0-255	Pan Control Fine
20	17	Tilt	0-255	Tilt Control
21	18	Tilt Fine	0-255	Tilt Control Fine
22	19	PT Speed	0-128	Fast to Slow
			129-170	Slow (1/3 Speed)
			171-211	Medium (1/2 Speed)
			212-255	Fast Speed (Full Speed)
23	20	N/A		
24	21	Control	0-127	N/A
			128-255	Reset ALL

3. Maintenance

Routine Maintenance

The cleaning of lens must be carried out periodically to optimize light output. Cleaning frequency depends on the environment in which the fixture operates: damp, smokey, or particularly dirty surrounding can cause greater accumulation of dirt on the fixture's optics.

- Clean with a damp, soft cloth..
- Always dry the parts carefully.
- Clean the external optics at least every 20 days in demanding environments.

Troubleshooting Problems

The following are a few common problems that may occur during operation. Here are some suggestions for easy troubleshooting:

A. The unit does not work:

- Check that the unit is plugged in to a working power connector.
- Press the menu button to confirm that the unit is powered on. If the screen does not light up, the unit has no power.

B. Not Responding to the DMX Controller

- Check DMX cables to verify that they are plugged in and functional.
- Check the DMX address and mode – does it match the address and mode patched in the lighting console or software?
- Plug the light directly into the DMX controller with a cable that you know is good. Unplug all other lights – does it work?
- Try to use another DMX controller.

4. Technical Specifications

- Power Supply: AC100-240v 50/60hz Autoranging
- Power: 500w.
- USITT DMX 512 Signal with RDM
- DMX Signal Connection – 3 Pin Input and Output, Fixed Cables
- Weight – 22kgs / 48.6 Lbs
- Size (mm) – 304x339x680

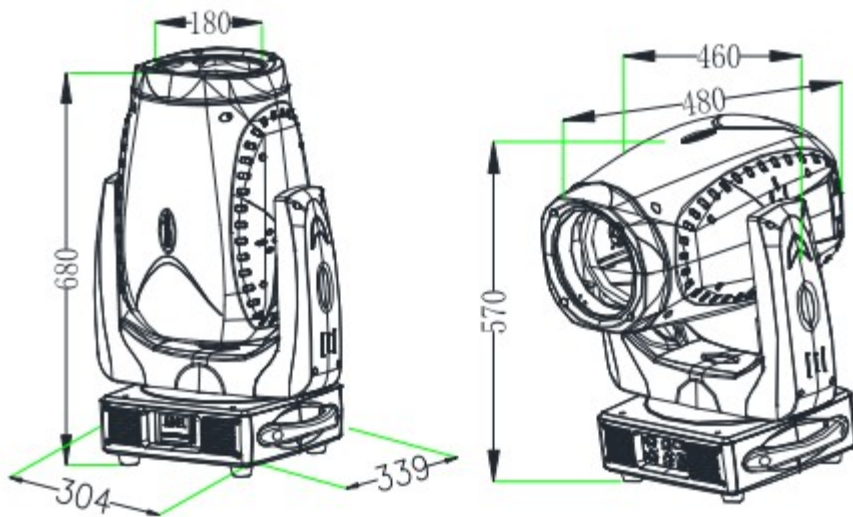

5. Photometrics

Zoom In, Focused: 1.3°

Distance in Ft.	Full White Intensity in FC
10	10700
15	5920
20	3320
25	2140
50	535

Zoom Out, Focused: 23°

Distance in Ft.	Full White Intensity in FC
5	2250
10	552
15	249
20	156
25	100
50	25

Zoom 50%, Focused: 8.6°

Distance in Ft.	Full White Intensity in FC
5	13900
10	3610
15	1760
20	1040
25	652
50	163

CRI, TM-30, and Spectral Distribution:

7180k Native Color Temperature

