

# Luxé Toro 600 RGBW

*RGBAL 600w LED Spot*



*User Manual*

## Table of Contents

1. Introduction and Setup.....	3
Unpacking and In the Box.....	3
Mounting and Operation.....	3
Safety Precautions.....	3
Customer Support.....	5
2. Setup and Operation.....	6
DMX Setup.....	8
DMX Basics.....	8
DMX Wiring.....	8
DMX Modes and Configuration.....	10
3. Maintenance.....	12
Routine Maintenance.....	12
Troubleshooting Problems.....	12
4. Technical Specifications.....	13
Photometric Reports.....	14

# 1. Introduction and Setup

## Unpacking and In the Box

Thank you for choosing our Luxé Toro 600 RGBAL. For your own safety, please read this manual before installing or using the device. This manual covers the important information on installation and applications. Please install and operate the fixture with following instructions. Meanwhile, please keep this manual for future needs.

In the box you will receive:

- Luxé Toro 600 RGBAL: 1
- 5 Pin DMX Cable: 1
- PowerCon Power Cable 1m 1

## Mounting and Operation

Use a clamp rated for the full weight of the Luxé Toro 600 RGBAL to hang the fixture from the mount(s) on the fixture's yoke.

As an added safety measure be sure to attached at least one properly rated safety cable to the fixture using on of the safety cable rigging point integrated in the base assembly or on the yoke.

## Safety Precautions

Caution: For added protection mount the fixtures in areas outside walking paths, seating areas, or in areas were the fixture might be reached by unauthorized personnel.

Before mounting the fixture to any surface, make sure that the installation area can hold a minimum point load of 10 items the device's weight.

Fixture installation must always be secured with a secondary safety attachment, such as an appropriate safety cable.

Do not clamp the safety cable to the U bracket or clamp. That is not a secondary safety point.

A secondary safety point is any point that will adequately hold the led profile spotlight if the clamp fails.

Then the safety cable would be the backup and stop the fixture from falling to the ground. So do NOT fix the safety cable to the same place that the C-Clamp is attached

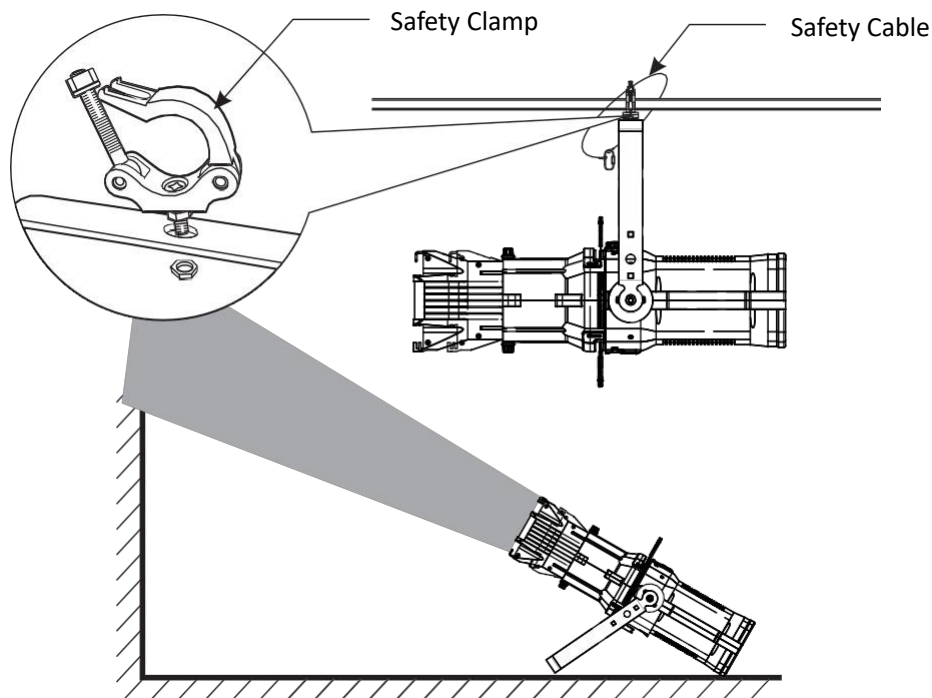

Never stand directly below the device when mounting, removing, or servicing the fixture.

From a ceiling, or set on a flat level surface (see illustration below). Be sure this fixture is kept at least 0.5m (1.5ft) away from any flammable materials (decoration etc.).

Always use and install the supplied safety cable as a safety measure to prevent accidental damage and/or injury in the event the clamp fails.

- Don't try to modify the fixture without any instruction by the manufacturer or the appointed repairing agencies.
- Warranty is voided if there are any malfunctions from not following the user manual while operating or any hazardous operation, like shock short circuit, electronic shock, lamp broken, etc.

# Customer Support

## WARRANTY POLICY

GAMMA LED Vision warrants its products for the periods set below from the date of purchase to be free of manufacturer and workmanship defects. Warranty does not cover normal wear and tear caused by force, negligence or misuse of products. GAMMA LED Vision is not responsible for any damages or injury caused by misuse or improper handling of the products and in accordance with instructions and specifications of manual.

Warranty terms are as follows:

LED Fixtures:

Indoor: 2 Years

Outdoor (IP 54 or higher): 1 Year

Lamp Fixtures: 1 year / excludes the lamp

LED Video Products:

Indoor: 2 Years

Outdoor (IP 54 or higher): 1 Year

Controllers: 2 years

Batteries: 6 months

All Trussing Related Products and Accessories: 1 Year

Please visit [WWW.GAMMALEDVISION.COM](http://WWW.GAMMALEDVISION.COM) for complete Limited Warranty terms and contact information.

## 2. Setup and Operation

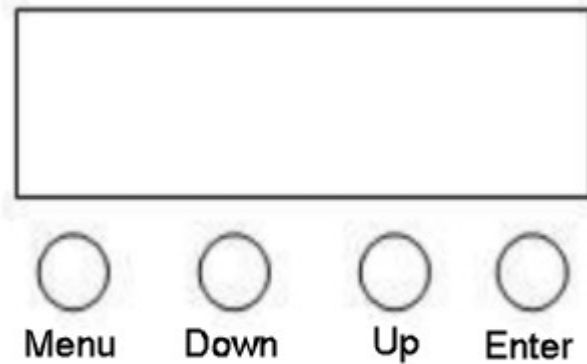

The LCD system includes Menu, Down, Up, and Enter buttons. Press "Menu" to enter the menu or to go back from a sub-menu. Use "Up"/"Down" to navigate through the choices, and use "Enter" to save your choices. *Note, the options below are numbered, and the "Up" key brings you forward in number, which is down on the screen.*

The menu options are as follows:

Menu Option	Second Menu	Value	Description
1. DMX Addr		001-512	Set the DMX address. Menu item <b>MUST</b> be selected for DMX control.
2. Key-CCT ( <b>This mode is a manual, variable-white mode</b> )	Bright	000-255	Set the brightness
	CCT	2700k-10,000k	Set the Color Temperature
3. Manual ADJ ( <b>This mode is a manual, full color mode</b> )	ALL-DIM	000-255	Full Intensity Control
	RED-DIM	000-255	Red Intensity Control
	GREEN-DIM	000-255	Green Intensity Control
	BLUE-DIM	000-255	Blue Intensity Control
	AMBER-DIM	000-255	Amber Intensity Control
	LIME-DIM	000-255	Lime Intensity Control
4. Test Mode	Prog	01-11	Choose the test program
	Prog Speed	01-16	Set the test program speed
	Test	Auto, Sound	Set whether the test program runs on auto or sound-active mode.
5. Setting	LCD Inverse	OFF/ON	Flip the LCD screen for inverted hanging positions.
	Back Light	OFF/ON	"ON" keeps backlight on 100% of the time, "OFF" sets backlight to turn off when DMX is present.
	Language	EN/Chinese	Set the menu language. <b>Change with caution!</b>
6. System Info	View the Serial Number, Firmware Version, Date, Time, and Temperature of the Light		

## DMX Setup

### DMX Basics

DMX512 stands for digital multiplex 512. This means that 512 channels are controlled digitally through 1 data cable.

A channel is a set of 255 steps that are assigned to control attributes in each light. This may be a color like red, green or blue, and intensity, strobe, pan/tilt or other attributes.

Multiple sets of 512 “universes” may be used. Only 1 universe will travel on a DMX cable, but through networked DMX (Art-Net or sACN E1.31), many universes can travel over a network.

### DMX Wiring

DMX works by connecting 1 or multiple lights to the output of a DMX lighting console or software with a DMX interface.

DMX lights connect in what is called a “daisy-chain”. Your first DMX cable will plug its male DMX connector into the female DMX connector on your lighting console. The remaining female connector will then connect to the DMX input on your first light.

You may then connect your next fixture to the output of your first light, and continue the chain.

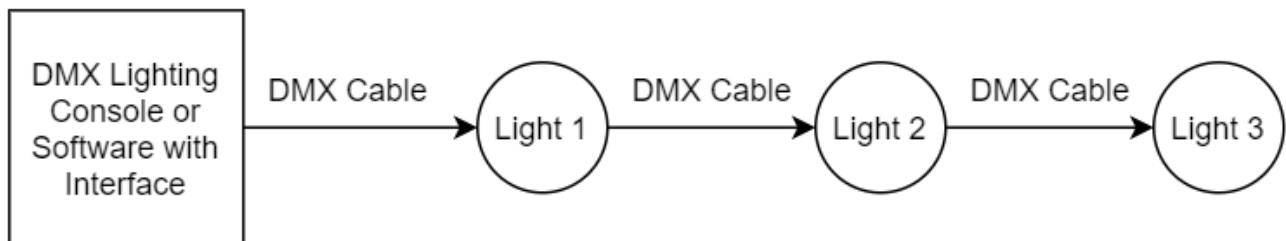

**32 Fixture Rule** – DMX only allows you to connect up to 32 fixtures in a single daisy chain for signal strength. Sometimes, depending on the fixtures and cable length, this number is less (or more).



DMX Cables can be 3-pin or 5-pin. These use the same type of data, and in the 5-pin only pins 1, 2, and 3 are used. The cable should be a 2 conductor, shielded cable of at least 110 ohms resistance. Microphone cable is not DMX cable.

Please refer to the diagram below:

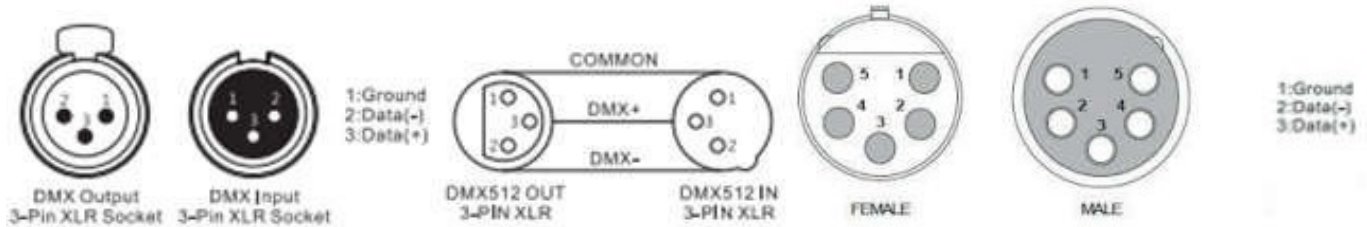

For installations where the DMX cable has to run a long distance or is in an electrically noisy environment, it is recommended to use a DMX terminator. This helps in preventing corruption of the digital control signal by electrical noise and reflections. The DMX terminator is simply an XLR plug with a 120 Ω resistor connected between pins 2 and 3, which is then plugged into the output XLR socket of the last fixture in the chain. Please see illustrations below:

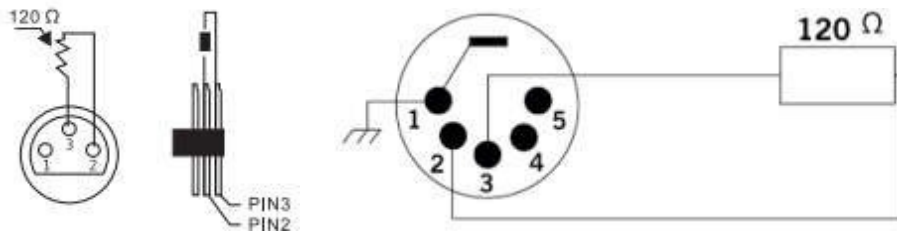

## DMX Modes and Configuration

The Luxé Toro 600 RGBAL has a single 10CH DMX mode.

On the left side of the sheet you will see the different modes and which channel corresponds to each function listed on the right in the given mode.

10CH	Function	Channel Value	Description
1	Dimmer	0-255	Master Dimmer
2	Color Temperature	0-255	Linear Color Temperature Control, 2700K to 10,000K
3	Color Mode	0-127	Variable White Mode – In this mode, Channel 2 determines the color temperature, individual color channel control is <b>disabled</b> on channels 4-8.
		128-255	Full Control Mode – In this mode, channel 4-8 provide RGBAL Control. Channel 2
4	Red	0-255	Red Intensity Control
5	Green	0-255	Green Intensity Control
6	Blue	0-255	Blue Intensity Control
7	Amber	0-255	Amber Intensity Control
8	Lime	0-255	Lime Intensity Control
9	Color Macros	0-20	No Function
		21-164	Static Color Macros
		165-255	Dynamic Color Macros
10	Macros Speed	0-255	Speed for Dynamic Color Macros, Fast to Slow

## **3. Maintenance**

### **Routine Maintenance**

#### **Fan Cleaning**

Periodically do a visual inspection of the fans. If they are dirty, power off the unit and use a small electronics vacuum to clean the fans out. Do not use a can of CO<sub>2</sub> or an Air Compressor. These will simply blow the dust into the unit and may leave other residue.

#### **Front Lens and Shutter Blade Cleaning**

The front lens should be cleaned so that light output is maintained. The shutter blades may also occasionally need cleaning.

With the light powered off, use a moist, lint-free cloth. Never use alcohol or solvents to clean the fixture.

Never spray any cleaners on the fixture.

### **Troubleshooting Problems**

The following are a few common problems that may occur during operation. Here are some suggestions for easy troubleshooting:

#### **A. The unit does not work:**

- Check that the unit is plugged in to a working power connector.
- Press the menu button to confirm that the unit is powered on. If the screen does not light up, the unit has no power.

#### **B. Not Responding to the DMX Controller**

- Check DMX cables to verify that they are plugged in and functional.
- Check the DMX address and mode – does it match the address and mode patched in the lighting console or software?
- Plug the light directly into the DMX controller with a cable that you know is good. Unplug all other lights – does it work?
- Try to use another DMX controller.

## 4. Technical Specifications

- 1\*600w RGBAL LED
- CRI 90
- 50,000 hours life and low power consumption
- Lens tube interchangeable with 26° lens (Other lens options available, contact your dealer for details)
- 0-100% Smooth and precise linear dimmer
- 9 DMX channel USITT DMX-512
- DMX512 and manual modes.
- 4-Button LCD display
- PowerCon connector IN/OUT
- 3-Pin XLR connectors IN/OUT
- Low noise fan
- 40°C Max ambient temperature
- IP20 protection rating
- AC100-230V 50-60HZ
- Max. Power: 220W
- Dimensions: 28"x12"x11"
- Net Weight: 25lbs

## Photometric Reports

26 Degree Lens – FC at Center

Distance	RGBAL at Full	High CRI 90 – See DMX Values used below
5'	1050	828
10'	302	220
15'	139	120
20'	79	60
30'	34	30
40'	20	15

### High CRI DMX Values:

Red – 127

Green – 6

Blue – 5

Amber – 255

Lime - 255

**CRI at 3245k = CRI 90**

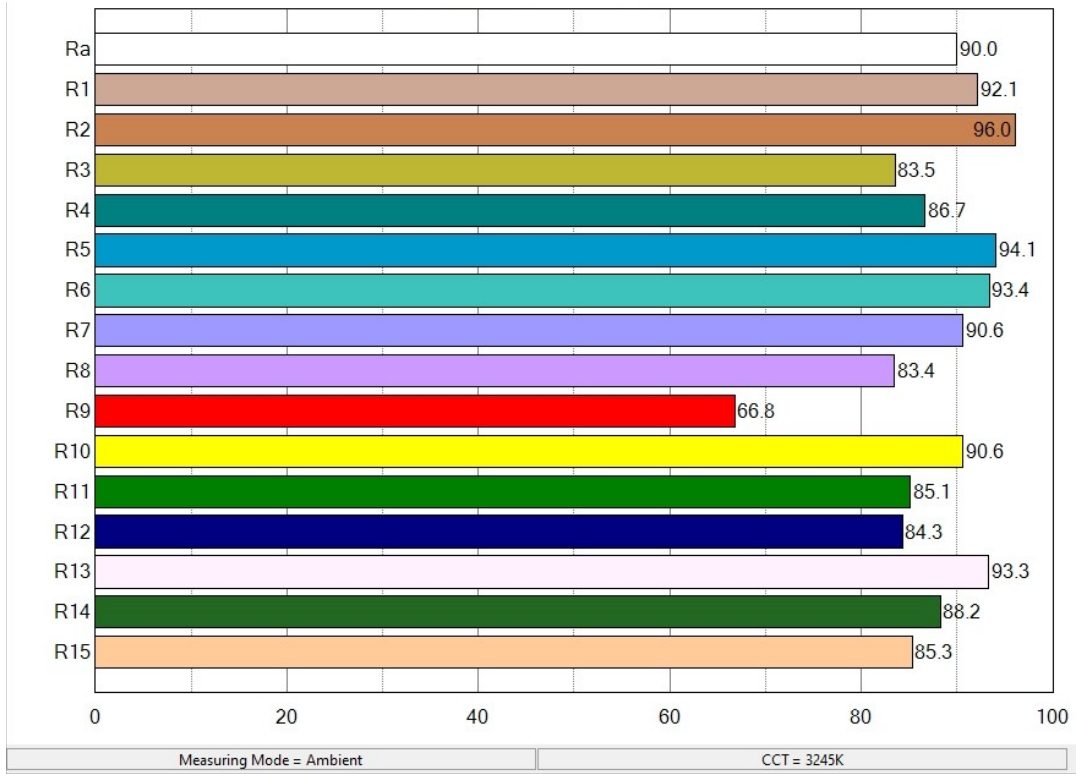

**TM30 at 3245k:**

