

Silhouette Borealis X Z

LED Moving Wash/Beam



User Manual



Table of Contents

- 1. Introduction and Setup.....3
 - Unpacking and In the Box.....3
 - Mounting and Operation.....3
 - Features.....3
 - Safety Precautions.....4
 - Customer Support.....5
- 2. Setup and Operation.....6
 - Using the LCD Menu and Buttons.....6
 - DMX Setup.....7
 - DMX Basics.....7
 - DMX Wiring.....7
 - DMX Modes and Configuration.....9
- 3. Maintenance.....14
 - Routine Maintenance.....14
 - Fixture Cleaning.....14
 - Troubleshooting Problems.....14
- 4. Technical Specifications.....16
 - Photometric Reports.....17

1. Introduction and Setup

Unpacking and In the Box

Thank you for choosing the Borealis X Z from GAMMA LED Vision. You will see you have acquired a powerful and versatile moving light.

Inside the box you should find:

- Borealis X Z Fixture: 1
- Omega Brackets 1
- DMX Cable 1
- 1m PowerCon to Edison Cable 1

(Flight case, Safety cable and Clamps are optional, please contact your dealer)

Please check carefully that there is no damage from shipping. Should there be any problems, please consult your dealer and don't use the light until you've verified it's good to go!

Mounting and Operation

Before installation, please read the user manual carefully, then prepare Omega Brackets (2 pcs), Clamps (2 pcs), and Safety Cable (1 pc).

Clamp Mounting: The Silhouette Borealis X Z provides a unique mounting bracket assembly that integrates the bottom of the base, and the safety cable rigging point in one unit.

When mounting this fixture to truss be sure to secure an appropriately rated clamp to the included omega bracket using a M10 screw fitted through the center hole of the omega bracket.

As an added safety measure be sure to attached at least one properly rated safety cable to the fixture using on of the safety cable rigging point integrated in the base assembly.

Features

- ◆ Extremely small, fast and powerful LED moving head.
- ◆ DMX Channels: 10CH, 15CH, 21CH, 37CH, and 39CH
- ◆ Ring Control in 3 Segments
- ◆ 10° -60° Zoom
- ◆ DMX Control
- ◆ Quiet Motors and Fans

Safety Precautions

Please keep this User Guide for future consultation. If you sell the unit to another user, be sure that they also receive this instruction manual.

Caution: For added protection mount the fixtures in areas outside walking paths, seating areas, or in areas where the fixture might be reached by unauthorized personnel.

Before mounting the fixture to any surface, make sure that the installation area can hold a minimum point load of 10 times the device's weight.

Fixture installation must always be secured with a secondary safety attachment, such as an appropriate safety cable.

Never stand directly below the device when mounting, removing, or servicing the fixture.

From a ceiling, or set on a flat level surface (see illustration below). Be sure this fixture is kept at least 0.5m (1.5ft) away from any flammable materials (decoration etc.).

Always use and install the supplied safety cable as a safety measure to prevent accidental damage and/or injury in the event the clamp fails.

DO NOT connect the device to any dimmer pack.

During initial start-up some smoke or smell may arise. This is a normal process and does not necessarily mean that the device is defective, and it will decrease gradually within 15 minutes.

·Don't try to modify the fixture without any instruction by the manufacturer.

·Warranty is voided if there are any malfunctions from not following the user manual while operating or any hazardous operation, like shock short circuit, electronic shock, lamp broken, etc.

Customer Support

WARRANTY POLICY

GAMMA LED Vision warrants its products for the periods set below from the date of purchase to be free of manufacturer and workmanship defects. Warranty does not cover normal wear and tear caused by force, negligence or misuse of products. GAMMA LED Vision is not responsible for any damages or injury caused by misuse or improper handling of the products and in accordance with instructions and specifications of manual.

Warranty terms are as follows:

LED Fixtures:

Indoor: 2 Years

Outdoor (IP 54 or higher): 1 Year

Lamp Fixtures: 1 year / excludes the lamp

LED Video Products:

Indoor: 2 Years

Outdoor (IP 54 or higher): 1 Year

Controllers: 2 years

Batteries: 6 months

All Trussing Related Products and Accessories: 1 Year

Please visit WWW.GAMMALEDVISION.COM for complete Limited Warranty terms and contact information.

2. Setup and Operation

Using the LCD Menu and Buttons

The Borealis X Z features a standard LCD screen and buttons for operation. Press **Menu** to enter the menu. Use the **Up** and **Down** arrows to navigate through the options and press **Enter** to go into the menu or confirm your selection. The menu will automatically exit after a period of inactivity.

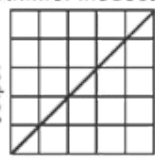
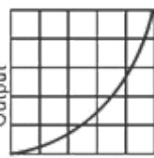
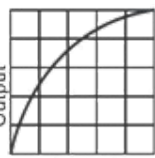
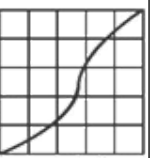
Menu		
DMX Address	001-512	Set the DMX starting address of the light.
Channl Set	10CH, 15CH, 21CH, 37CH, and 39CH	Set the DMX channel mode.
Show Mode	Show 01-04	Set the autoprogram mode.
Slave Mode	Master, Slave 1, Slave 2	Sets the master/slave mode for "Show Mode" operation with multiple fixtures connected via DMX cables.
Black Out	Yes, No	Set the preference for behavior at DMX loss. "Yes" makes the fixture blackout when DMX is lost, "No" puts the fixture into "Show Mode" when DMX is lost.
Sound Mode	Yes, No	Turns on Sound-Active mode.
Sound Sense	0-100	Sets the microphone sensitivity for sound-active mode.
Display Invert	Yes, No	Flips the display for hanging fixtures.
Pan Inverse	Yes, No	Inverts the pan.
Tilt Inverse	Yes, No	Inverts the tilt.
P/T Feedback	Yes, No	P/T Feedback moves the head back into place when it is knocked. You may turn it off via this menu, though it is not recommended in normal circumstances.
Bk P/T Moving	Yes, No	When "Yes" is set, the fixture will black out when it moves between positions.
Dimmer Curve	Linear, Square Law, Inverse Square Law, S-Curve	Set the dimmer curve as follows: <div style="display: flex; justify-content: space-around; align-items: flex-start;"> <div style="text-align: center;"> <p>Dimmer Modes:</p>  <p>DMX% (Optically Linear)</p> </div> <div style="text-align: center;">  <p>DMX% (Square Law)</p> </div> <div style="text-align: center;">  <p>DMX% (Inverse Square Law)</p> </div> <div style="text-align: center;">  <p>DMX% (S-Curve)</p> </div> </div>

Dimmer Freq	1200k, 2400k, 4000k, 6000k	Allows you to change the PWM frequency of the LED's.
Fan Speed	Auto, Slow, Height	Set the fan speed. Auto is recommended.
Back Light	On, Off	Sets the LCD Backlight to stay on or turn off when not in use.
White Balance	Red, Green, Blue	0-100 for each color – allows you to scale the maximum value of each color if desired. Use with care.
Language Setup	English, Chinese	Sets the menu language – USE WITH CAUTION! If you do set the language to Chinese (and you aren't a fluent reader), follow the order of the menu items here to find the language menu again and reset it to English.
RDM Infor		Displays RDM device information
Auto Test	Test...	Places the light into an auto-test function. Watch your fingers when you press "enter"!
Reset	All Reset, PT Reset, Zoom Reset	Allows you to reset parameters of the light.
Version		Displays the firmware versions of the internal components.

DMX Setup

DMX Basics

DMX512 stands for digital multiplex 512. This means that 512 channels are controlled digitally through 1 data cable.

A channel is a set of 255 steps that are assigned to control attributes in each light. This may be a color like red, green or blue, and intensity, strobe, pan/tilt or other attributes.

Multiple sets of 512 "universes" may be used. Only 1 universe will travel on a DMX cable, but through networked DMX (Art-Net or sACN E1.31), many universes can travel over a network.

DMX Wiring

DMX works by connecting 1 or multiple lights to the output of a DMX lighting console or software with a DMX interface.

DMX lights connect in what is called a "daisy-chain". Your first DMX cable will plug its male DMX connector into the female DMX connector on your lighting console. The remaining female connector will then connect to the DMX input on your first light.

You may then connect your next fixture to the output of your first light, and continue the chain.

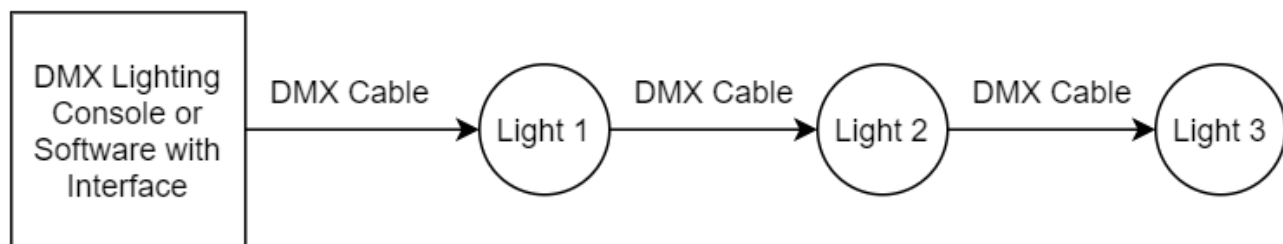

32 Fixture Rule – DMX only allows you to connect up to 32 fixtures in a single daisy chain for signal strength. Sometimes, depending on the fixtures and cable length, this number is less (or more).

DMX Cables can be 3-pin or 5-pin. These use the same type of data, and in the 5-pin only pins 1, 2, and 3 are used. The cable should be a 2 conductor, shielded cable of at least 110 ohms resistance. Microphone cable is not DMX cable. Please refer to the diagram below:

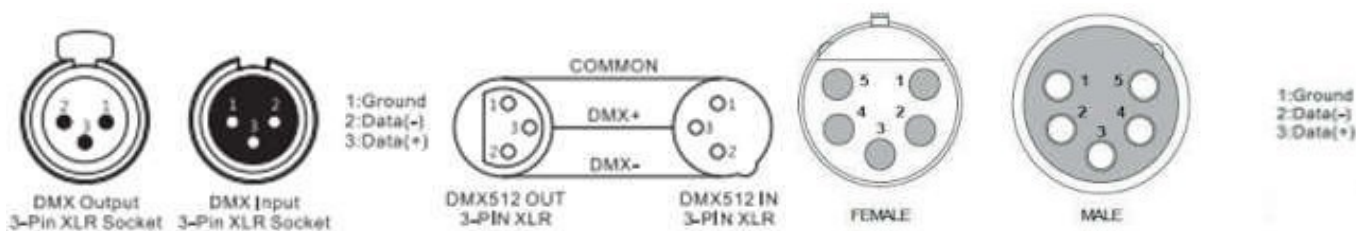

For installations where the DMX cable has to run a long distance or is in an electrically noisy environment, it is recommended to use a DMX terminator. This helps in preventing corruption of the digital control signal by electrical noise and reflections. The DMX terminator is simply an XLR plug with a 120 Ω resistor connected between pins 2 and 3, which is then plugged into the output XLR socket of the last fixture in the chain. Please see illustrations below:

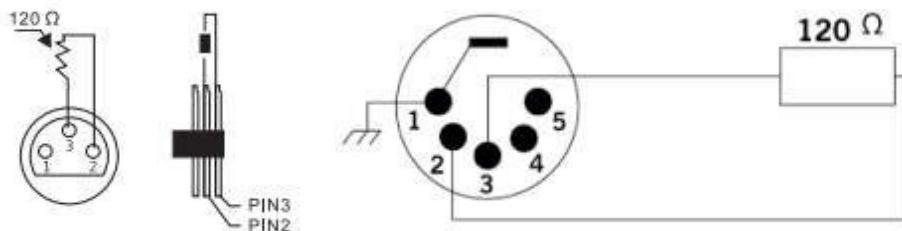

DMX Modes and Configuration

The Silhouette Borealis X Z has multiple DMX modes, sometimes called “personalities”, “profiles”, or as we will use here “modes”.

In general, modes with more DMX channels offer a greater level of control or options but take up more of your output channels on your lighting console or software.

Modes with less DMX channels often offer less control, but may be plenty for your needs. *Depending on your needs and control solution, you may not need channels for automated programs, strobes, or macros – your console may have great effects! In this case, you can use a lesser channel mode and fit more lights per DMX universe.*

The Borealis X Z offers a 10-channel “simple” mode, which is not recommended for most users as it lacks RGBW color mixing control.

The 15 and 21 channel modes offers full fixture control without ring control.

The 37 and 39 channel modes all offer full control of the rings, including macros on the 39 channel.

View the DMX mode charts below to find the mode that best suits your needs.

10CH	15CH	21CH	37CH	39CH	Function	Value	Description/Options
1	1	1	1	1	Pan	0-255	Pan Control
2	2	2	2	2	Pan Fine	0-255	Fine Pan Control
3	3	3	3	3	Tilt	0-255	Tilt Control
4	4	4	4	4	Tilt Fine	0-255	Fine Tilt Control
5	5	5	5	5	Pan Tilt Speed	0-255	Movement Speed, Fast to Slow
6	6	6	6	6	Control	0-69	No Function
						70-79	Move in Black Enabled (Fixture turns off when moving)
						80-89	Move in Black Off
						90-99	Invert Pan
						100-109	Invert Tilt

10CH	15CH	21CH	37CH	39CH	Function	Value	Description/Options
						110-119	Pan and Tilt Invert Off
						120-139	No Function
						140-149	Reset Pan and tilt
						150-179	No Function
						180-189	Reset Zoom
						190-199	No Function
						200-209	Reset All
						210-255	No Function
	7	7			Red	0-255	Red Control (Entire Fixture)
		8			Red Fine	0-255	Red Control Fine (Entire Fixture)
	8	9			Green	0-255	Green Control (Entire Fixture)
		10			Green Fine	0-255	Green Control Fine (Entire Fixture)
	9	11			Blue	0-255	Blue Control (Entire Fixture)
		12			Blue Fine	0-255	Blue Control Fine (Entire Fixture)
	10	13			White	0-255	White Control (Entire Fixture)
		14			White Fine	0-255	White Control Fine (Entire Fixture)
			14	7	Red 1	0-255	Inner Ring Red Intensity

10CH	15CH	21CH	37CH	39CH	Function	Value	Description/Options
			15	8	Red Fine 1	0-255	Inner Ring Red Intensity (Fine)
			16	9	Green 1	0-255	Inner Ring Green Intensity
			17	10	Green Fine 1	0-255	Inner Ring Green Intensity (Fine)
			18	11	Blue 1	0-255	Inner Ring Blue Intensity
			19	12	Blue Fine 1	0-255	Inner Ring Blue Intensity (Fine)
			20	13	White 1	0-255	Inner Ring White Intensity
			21	14	White Fine 1	0-255	Middle Ring White Intensity (Fine)
			22	15	Red 2	0-255	Middle Ring Red Intensity
			23	16	Red Fine 2	0-255	Middle Ring Red Intensity (Fine)
			24	17	Green 2	0-255	Middle Ring Green Intensity
			25	18	Green Fine 2	0-255	Middle Ring Green Intensity (Fine)
			26	19	Blue 2	0-255	Middle Ring Blue Intensity
			27	20	Blue Fine 2	0-255	Middle Ring Blue Intensity (Fine)
			28	21	White 2	0-255	Middle Ring White Intensity
			29	22	White Fine 2	0-255	Middle Ring White Intensity (Fine)
			30	23	Red 3	0-255	Outer Ring Red Intensity
			31	24	Red Fine 3	0-255	Outer Ring Red Intensity (Fine)
			32	25	Green 3	0-255	Outer Ring Green Intensity
			33	26	Green Fine 3	0-255	Outer Ring Green Intensity (Fine)

10CH	15CH	21CH	37CH	39CH	Function	Value	Description/Options
			34	27	Blue 3	0-255	Outer Ring Blue Intensity
			35	28	Blue Fine 3	0-255	Outer Ring Blue Intensity (Fine)
			36	29	White 3	0-255	Outer Ring White Intensity
			37	30	White Fine 3	0-255	Outer Ring White Intensity (Fine)
	11	15	12	31	Color Temperature Control	0	No Function
						1-255	2700k-8000k . CTC channel overrides any color selection from the RGB channels and gives you a calibrated white.
7	12	16	13	32	Virtual Color Wheel	0	No Function
						1-3	2700k White
						4-6	3200k White
						7-9	4200k White
						10-12	5600k White
						13-15	8000k White
						16-247	Virtual Hue Wheel
						248-255	No Function
8	13	17	7	33	Zoom	0-255	Zoom Control
		18	8	34	Zoom Fine	0-255	Fine Zoom Control
9	14	19	9	35	Strobe	0-15	No Function
						16-131	Strobe, Slow to Fast
						132-139	Lighting Strobe
						140-	Pulse-Closed Strobe

10CH	15CH	21CH	37CH	39CH	Function	Value	Description/Options
						181	
						182-189	No Function
						190-231	Pulse-Open Strobe
						232-239	No Function
						240-247	Random Strobe
						248-255	No Function
10	15	20	10	36	Dimmer	0-255	Intensity Control
		21	11	37	Dimmer Fine	0-255	Fine Intensity Control
				38	Macros	0-7	No Function
						8-255	Macros
				39	Macro Speed	0-255	Macros Speed

3. Maintenance

Routine Maintenance

Fixture Cleaning

The cleaning of internal and external optical lenses and/or mirrors must be carried out periodically to optimize light output. Cleaning frequency depends on the environment in which the fixture operates: damp, smoky or particularly dirty surroundings can cause greater accumulation of dirt on the unit's optics.

- ◆ Clean with soft, damp cloth.
- ◆ Always dry the parts carefully.
- ◆ Clean the external optics at least every 20 days.

Use an air compressor (oil-free) or electronics vacuum to clean the fan inlets and outlets when you notice they are dusty or dirty. Like any other electronics fan, always use an object to block the fan from spinning while you clean it, and blow air so that the dirt blows out of the fixture!

Troubleshooting Problems

The following are a few common problems that may occur during operation. Here are some suggestions for easy troubleshooting:

A. The unit does not work and you do not hear any fans running when it's plugged in:

- Check that the unit is plugged in to a working power outlet.
- Press the menu button to confirm that the unit is powered on. If the screen does not light up, the unit has no power.

B. Not Responding to the DMX Controller

- Check DMX cables to verify that they are plugged in and functional.

- Check the DMX address and mode – does it match the address and mode patched in the lighting console or software?
- Plug the light directly into the DMX controller with a cable that you know is good. Unplug all other lights – does it work?
- Try to use another DMX controller.

C. One of the functions is not working well

- The stepper motor might be damaged or the cable connected to the PCB is broken.
- The motor's drive IC on the PCB may be bad.

4. Technical Specifications

- Small, fast, and powerful moving head light with RGBW Color Mixing
- Motorized Zoom from 10° -60°.
- Multiple DMX modes.
- AC100-240v, 50/60Hz autosensing
- 475w total power consumption, 19 x 25w LED's
- Power-Chain up to 8 fixtures (230v, 50hz), or 4 fixtures (120v, 60hz)
- Weight – 22 lbs / 9.98kgs
- Dimensions: 13.7" x 10" x 15.8" 350x255x400mm
- Box Size: 18.5" x 10.5" x 22.2" 470x265x565mm

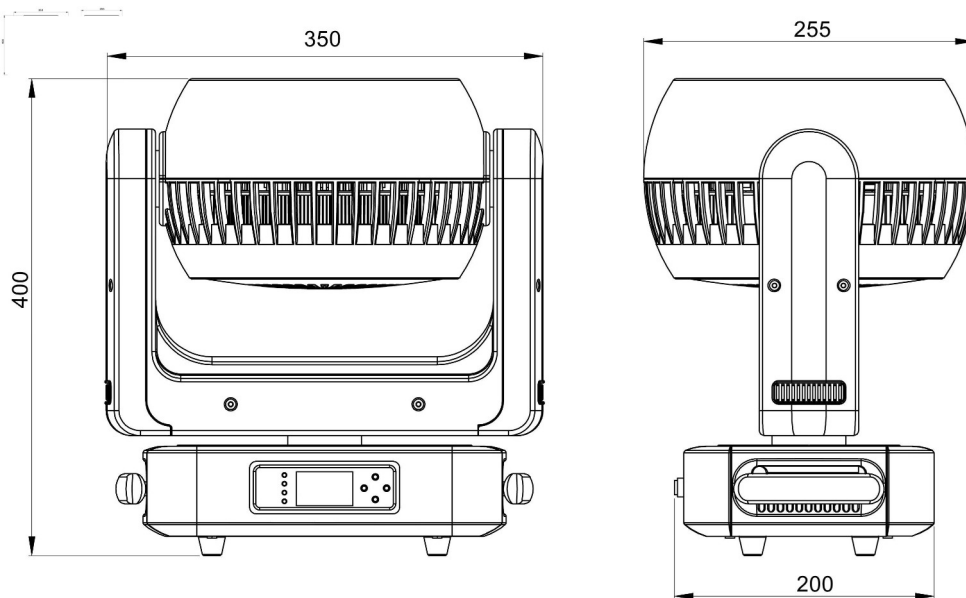

Photometric Reports

Full Zoom - 60°

Distance in Ft.	Full White Intensity in FC	High CRI White Intensity in FC – 10,000k
5	583	621
10	148	148
15	68	67
20	41.1	39
25	31	26

Half Zoom - 30°

Distance in Ft.	Full White Intensity in FC	High CRI White Intensity in FC – 10,000k
5	1480	1380
10	361	361
15	171	155
20	95	90
25	66	64

Min. Zoom - 10°

Distance in Ft.	Full White Intensity in FC	High CRI White Intensity in FC – 10,000k
5	6300	4810
10	1690	1600
15	812	775
20	466	456
25	320	315

CRI: 10,303k

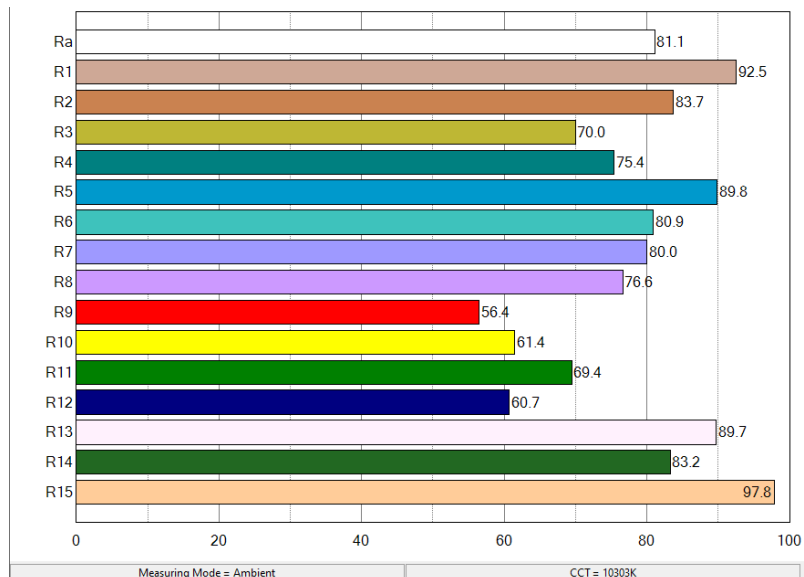

TM-30

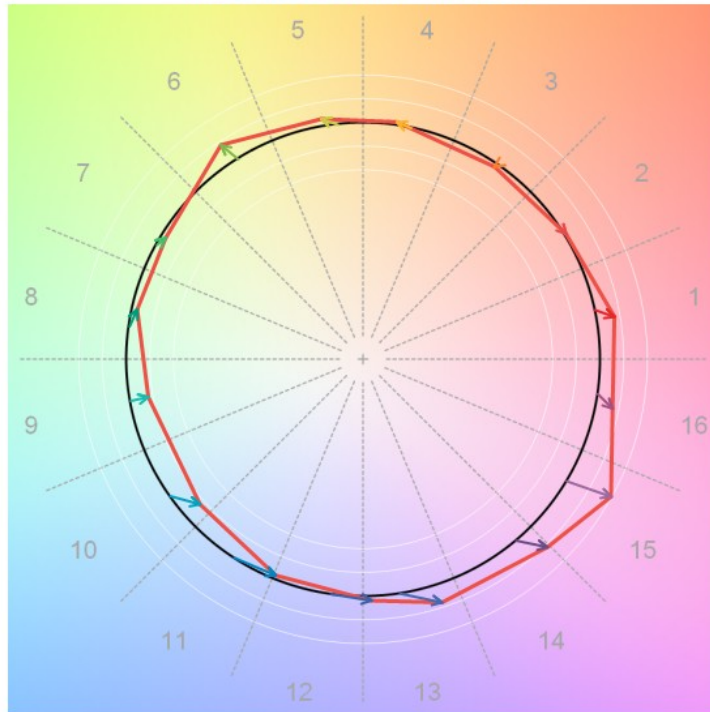

TM-30-18 Vector Graphic

Measuring Mode = Ambient		CCT = 10303K	
Rf = 83	Rg = 106	Ra = 81.1	