

TX5 Hybrid

250w Hybrid Moving Head with Zoom



CE ∇ \oplus IP20 LED \leftarrow 0.2m \rightarrow t₀ 40°C t₁ 150°C

User Manual



Table of Contents

1. Introduction and Setup.....	3
2. Setup and Operation.....	10
DMX Basics.....	11
DMX Wiring.....	11
3. Maintenance.....	17
Routine Maintenance.....	17
Troubleshooting Problems.....	18
4. Technical Specifications.....	19

1. Introduction and Setup

Unpacking and In the Box

Thank you for choosing our TX5 Hybrid moving head light. For your own safety, please read this manual before installing or using the device. This manual covers the important information on installation and applications. Please install and operate the fixture with following instructions. Meanwhile, please keep this manual for future needs.

The TX5 is made of a new type of high temperature strength plastic and cast aluminum casing. The fixture is designed and manufactured strictly following CE standards, complying with international standard DMX512 protocol. It's independently controllable and link-able with other lights for operation. And it is applicable for large-scale live performances, theater, studio, nightclubs, houses of worship, and more.

The TX5 features high brightness and stability. Please carefully unpack it when you receive the fixture and check for any damages from shipping. And please check whether the following items are included inside the box:

-



- TX-5 250w Moving Head – 1
- DMX Signal Cable – 1
- Power Cable – 1
- Omega Clamps – 2
- User Manual - 1

Mounting and Operation

Caution: For added protection mount the fixtures in areas outside walking paths, seating areas, or in areas where the fixture might be reached by unauthorized personnel.

Before mounting the fixture to any surface, make sure that the installation area can hold a minimum point load of 10 times the device's weight.

Fixture installation must always be secured with a secondary safety attachment, such as an appropriate safety cable.

Never stand directly below the device when mounting, removing, or servicing the fixture.

From a ceiling, or set on a flat level surface (see illustration below). Be sure this fixture is kept at least 0.5m (1.5ft) away from any flammable materials (decoration etc.).

Always use and install the supplied safety cable as a safety measure to prevent accidental damage and/or injury in the event the clamp fails.

Mounting points: Overhead mounting requires extensive experience, including amongst others calculating working load limits, a fine knowledge of the installation material being used, and periodic safety inspection of all installation material and the fixture. If you lack these qualifications, do not attempt the installation yourself. Improper installation can result in bodily injury.

Be sure to complete all rigging and installation procedures before connecting the main power cord to the appropriate wall outlet.

Clamp Mounting: The TX5 provides a unique mounting bracket assembly that integrates the bottom of the base, and the safety cable rigging point in one unit (see the illustration below).

When mounting this fixture to truss be sure to secure an appropriately rated clamp to each of the included omega brackets using a M10 screw fitted through the center hole of the "omega bracket". As an added safety measure be sure to attached at least one properly rated safety cable to the fixture using on of the safety cable rigging point integrated in the base assembly.

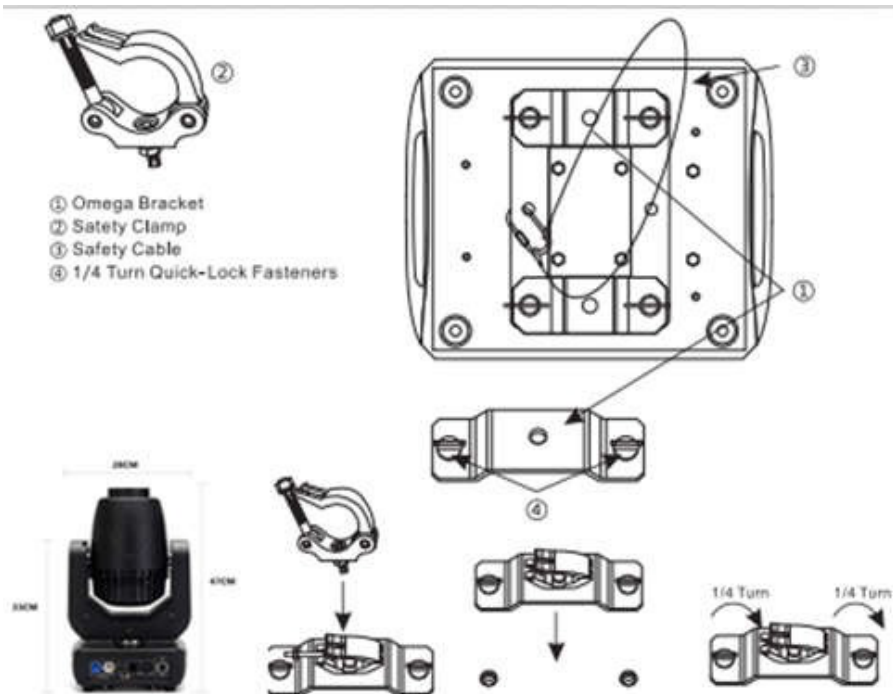

Regardless of the rigging option you choose for your TX5 Hybrid, always be sure to secure your fixture with a safety cable. The fixture provides a built-in rigging point for a safety cable on the hanging bracket as illustrated above. Be sure to only use the designated rigging point for the safety cable and never secure a safety cable to a carrying handle.

- The moving head is for spot effect for on-site decoration purpose.
So make sure to operate the fixture until it is in normal temperature.
- This light should be keep away from strong shaking during any transportation or movement.
- Don't pull up the light by only the head, or it might cause damages to the mechanical parts.
- Don't expose the fixture in overheating, moisture or environments with too much dust when installing it.
- Make sure the installation environment is in good safety condition before installing the fixture.

- Make sure to put the safety chain and check whether the screws/clamps are screwed properly when installing the fixture.
- Make sure the lens are in good condition. It's recommended to replace the units if there are any damages or severe scratches.
- Make sure the fixture is operated by qualified personnel who know the fixture before using.
- Keep the original packaging in case there is any future need for any warranty repair or service.
- Don't try to modify the fixtures without any instruction by the manufacturer or the appointed repairing agencies.
- Warranty is voided if there are any malfunctions from not following the user manual while operating or any hazardous operation, like shock short circuit, electronic shock, lamp broken, etc.

Features

- 250W High Output White LED
- 50,000 hour lifespan and lower power consumption
- 5.5°-30° Beam Angle with focus function
- High light output: 13300 LUX@5M in White light, Zoomed In
- Overtemp protection: When the internal temperature hits 40°C and then the fans begin to work, if the internal temperature hits 70°C, the brightness reduces to half until it cools.
- Color Wheel: 7 colors +white, rotation with variable direction and speed
- 1 static Gobo Wheel: 8 gobos +white, wheel rotation and shake
- 1 Rotating Gobo Wheel: 6 gobos +white, wheel rotation and shake
- Prism: 3-facet Prism, bi-directionally rotatable at variable speeds
- High speed strobe effect with 1-25 hz
- Internal program available
- 16/18 DMX Channels USITT DMX-512
- DMX 512, master-slave and sound activated controllable or auto operation
- Colorful LCD display

- Efficient low noise fan cooling system
- PowerCon IN/OUT
- 3-pin XLR connectors IN/OUT
- Two 1/4 turn fastening Omega Clamps
- IP 20 protection rating

Safety Precautions



CAUTION

Be careful with your operations. With a dangerous voltage you can suffer a dangerous electric shock when touching wires!

This device has left the factory in perfect condition. In order to maintain this condition and to ensure a safe operation, it is absolutely necessary for the user to follow the safety instructions and warning notes written in this user manual.



IMPORTANT

Damages caused by the disregard of this user manual are not subject to warranty. The dealer will not accept liability for any resulting defects or problems.

If the device has been exposed to temperature changes due to environmental changes, do not switch it on immediately. The arising condensation could damage the device.

This light should be kept away from strong shaking during any transportation or movement.

Don't pull up the light by only the head, or it might cause damages to the mechanical parts.

Leave the device switched off until it has reached room temperature.

This device falls under protection-class I. Therefore it is essential that the device be earthed. The electric connection must be carried out by a qualified person.

The device shall only be used with rated voltage and frequency.

Make sure that the available voltage is not higher than stated at the end of this manual.

Make sure the power cord is never crimped or damaged by sharp edges. If this would be the case, replacement of the cable must be done by an authorized dealer.

Always disconnect from the mains, when the device is not in use or before cleaning it.

Only handle the power cord by the plug. Never pull out the plug by tugging the power cord.

During initial start-up some smoke or smell may arise. This is a normal process and does not necessarily mean that the device is defective, it should decrease gradually.

Please don't project the beam onto combustible substances.

Fixtures cannot be installed on combustible substances, keep more than 50cm distance with wall for smooth air flow, so there should be no shelter for fans and ventilation for heat radiation.

If the external flexible cable or cord of this fixture is damaged, it shall be exclusively replaced by the manufacturer or his service agent or a similar qualified person in order to avoid a hazard.

Don't expose the fixture in overheating, moisture or environments with too much dust when installing it. And don't lay any power cables on the floor. Or it might cause electronics shock to the people.

Customer Support

WARRANTY POLICY

GAMMA LED Vision warrants its products for the periods set below from the date of purchase to be free of manufacturer and workmanship defects. Warranty does not cover normal wear and tear caused by force, negligence or misuse of products. GAMMA LED Vision is not responsible for any damages or injury caused by misuse or improper handling of the products and in accordance with instructions and specifications of manual.

Warranty terms are as follows:

LED Fixtures:

Indoor: 2 Years

Outdoor (IP 54 or higher): 1 Year

Lamp Fixtures: 1 year / excludes the lamp

LED Video Products:

Indoor: 2 Years

Outdoor (IP 54 or higher): 1 Year

Controllers: 2 years

Batteries: 6 months

All Trussing Related Products and Accessories: 1 Year

Please visit WWW.GAMMALEDVISION.COM for complete Limited Warranty terms and contact information.

2. Setup and Operation

Using the LCD Menu and Buttons

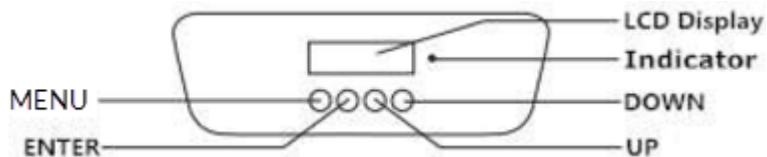

Menu Operation

Address Set → [Set Address Numbers]

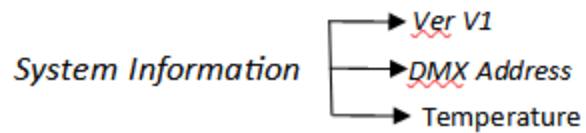
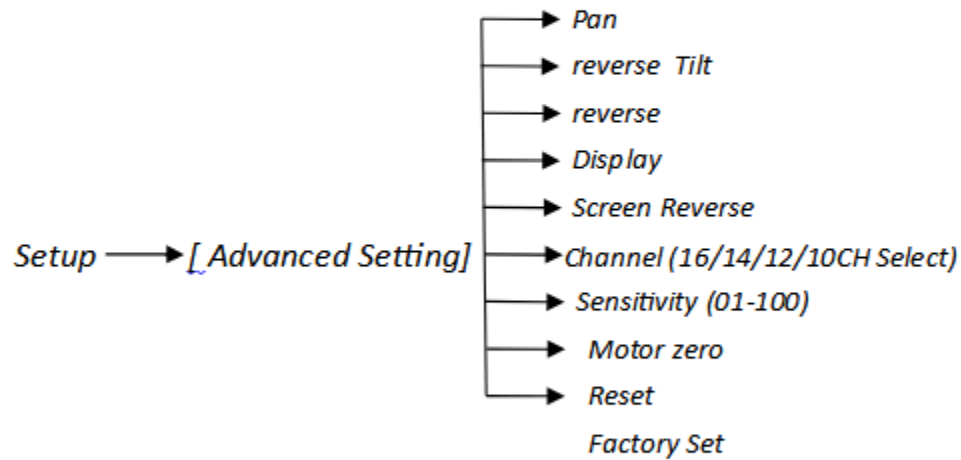
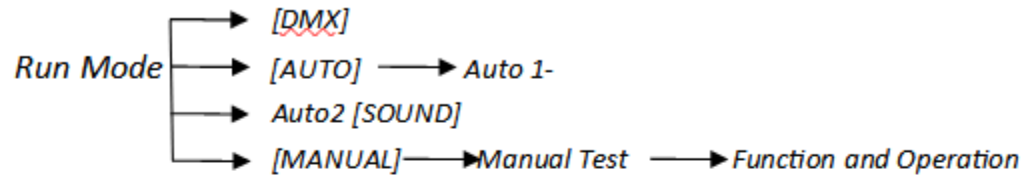

DMX Setup

DMX Basics

DMX512 stands for digital multiplex 512. This means that 512 channels are controlled digitally through 1 data cable.

A channel is a set of 255 steps that are assigned to control attributes in each light. This may be a color like red, green or blue, and intensity, strobe, pan/tilt or other attributes.

Multiple sets of 512 “universes” may be used. Only 1 universe will travel on a DMX cable, but through networked DMX (Art-Net or sACN E1.31), many universes can travel over a network.

DMX Wiring

DMX works by connecting 1 or multiple lights to the output of a DMX lighting console or software with a DMX interface.

DMX lights connect in what is called a “daisy-chain”. Your first DMX cable will plug its male DMX connector into the female DMX connector on your lighting console. The remaining female connector will then connect to the DMX input on your first light.

You may then connect your next fixture to the output of your first light, and continue the

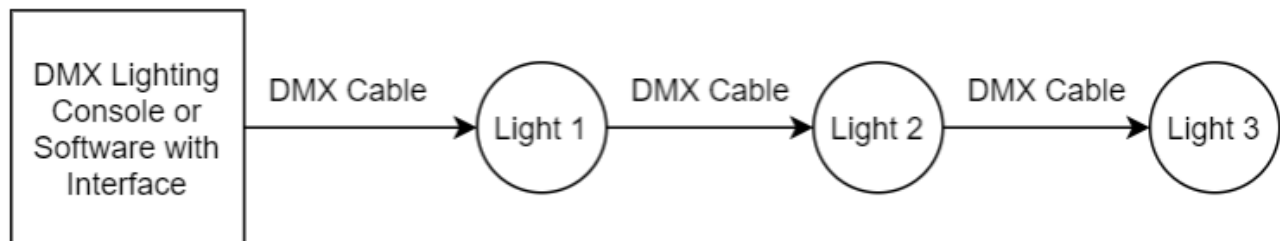

chain.

32 Fixture Rule – DMX only allows you to connect up to 32 fixtures in a single daisy chain for signal strength. Sometimes, depending on the fixtures and cable length, this number is less (or more).

DMX Cables can be 3-pin or 5-pin. These use the same type of data, and in the 5-pin only pins 1, 2, and 3 are used. The cable should be a 2 conductor, shielded cable of at least 110 ohms resistance. Microphone cable is not DMX cable.

Please refer to the diagram below:

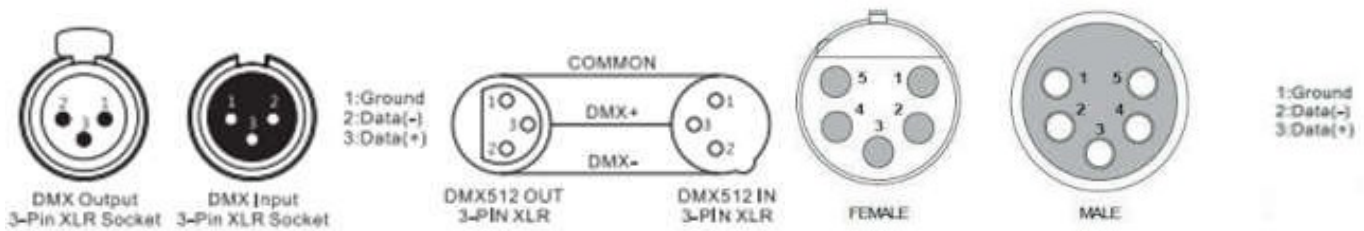

For installations where the DMX cable has to run a long distance or is in an electrically noisy environment, it is recommended to use a DMX terminator. This helps in preventing corruption of the digital control signal by electrical noise and reflections. The DMX terminator is simply an XLR plug with a 120 Ω resistor connected between pins 2 and 3, which is then plugged into the output XLR socket of the last fixture in the chain. Please see illustrations below:

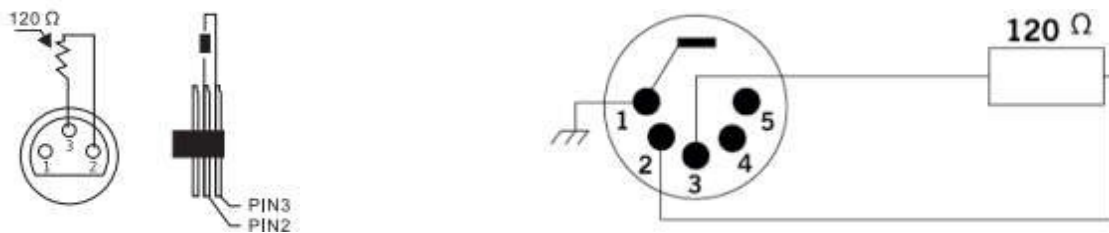

DMX Modes and Configuration

The TX5-250 Hybrid has multiple DMX modes, sometimes called "personalities", "profiles", or as we will use here "modes".

In general, modes with more DMX channels offer a greater level of control or options but take up more of your output channels on your lighting console or software.

Modes with less DMX channels often offer less control, but may be plenty for your needs. *Depending on your needs and control solution, you may not need channels for automated programs, strobes, or macros – your console may have great effects! In this case, you can use a lesser channel mode and fit more lights per DMX universe.*

View the DMX mode charts below to find the mode that best suits your needs.

DMX Channel Mode Sheet:

On the left side of the sheet you will see the different modes and which channel corresponds to each function listed on the right in the given mode.

18CH	16CH	Function	Channel Value	Description
1	1	Pan	0-255	0-540°
2		Pan Fine	0-255	Pan Fine
3	2	Tilt	0-255	0-270°
4		Tilt Fine	0-255	Tilt Fine
5	3	Movement Speed	0-255	Fast to slow
6	4	Intensity	0-255	Dimmer Control
7	5	Strobe	0-7	Strobe off
			8-250	Strobe, Slow to Fast
			251-255	Strobe off
8	6	Color Wheel	0-15	No Color/White
			16-31	Red
			32-47	Green
			48-63	Yellow
			64-79	Deep Blue/Indigo
			80-95	Magenta
			96-111	Amber
			112-127	Cyan
			128-191	CW scroll, slow to fast
192-255	CCW scroll, slow to fast			
9	7	Color	0-10	No Function

		Indexing	11-209	Color Index (Allows for variable splits between any 2 colors on the wheel)
10	8	Gobo Wheel 1 – Static	0-6	Open
			7-13	Gobo 1
			14-20	Gobo 2
			21-27	Gobo 3
			28-34	Gobo 4
			35-41	Gobo 5
			42-48	Gobo 6
			49-55	Gobo 7
			56-63	Gobo 8
			64-70	Gobo 8 Shake
			71-77	Gobo 7 Shake
			78-84	Gobo 6 Shake
			85-91	Gobo 5 Shake
			92-98	Gobo 4 Shake
			99-105	Gobo 3 Shake
			106-112	Gobo 2 Shake
			113-119	Gobo 1 Shake
			120-127	Open
			128-191	Gobo Scroll CW from Slow to Fast
192-255	Gobo Scroll CCW from Slow to Fast			

11	9	7 Rotating Gobos + White	0-15	Open
			16-31	Gobo 1
			32-47	Gobo 2
			48-63	Gobo 3
			64-79	Gobo 4
			80-95	Gobo 5
			96-111	Gobo 6
			112-127	Gobo 7
			128-191	Gobo Rotate CW from Slow to Fast
			192-255	Gobo Rotate CCW from Slow to Fast
12	10	Gobo Rotation	0-15	Open
			16-95	Gobo Fine 0-250
			96-135	Gobo Rotation 0-90°
			136-155	Gobo Rotation 0-250°
			156-175	Gobo Rotation 0-360°
			176-215	Gobo Scroll CW Slow to Fast
			216-255	Gobo Scroll CCW Slow to Fast
13	11	Focus	0-255	Soft to sharp
14	12	Zoom	0-255	Narrow to Wide, 5.5°-30°
15	13	Prism	0-63	Open
			64-255	Prism In
16	14	Prism	0-15	Stop

		Rotation	16-95	Prism Index 0-250°
			96-135	Prism Bounce 0-90°
			136-155	Prism Bounce 0-250°
			156-175	Prism Bounce 0-360°
			176-215	Prism Rotate CW, Slow to Fast
			216-255	Prism Rotate CCW, Slow to Fast
17	15	Frost	0-4	Open
			5-127	Variable Frost
			128-191	Frost Shake
			192-255	Frost Effect
18	16	Automatic Programs and Reset	0-7	No Function
			8-131	Auto Programs
			132-249	Sound-Active Mode
			250-253	Reset
			254-255	No Function

3. Maintenance

Routine Maintenance

The following points have to be considered during the inspection:

1) All screws for installing the devices or parts of the device have to be tightly connected and must not be corroded.

2) There must not be any deformations on the housing, color lenses, fixations and installation spots (ceiling, suspension, trussing).

3) Mechanically moved parts must not show any traces of wearing and must not rotate with unbalances.

4) The electric power supply cables must not show any damage, material fatigue or sediments.

Further instructions depending on the installation spot and usage have to be adhered by a skilled installer and any safety problems have to be removed.

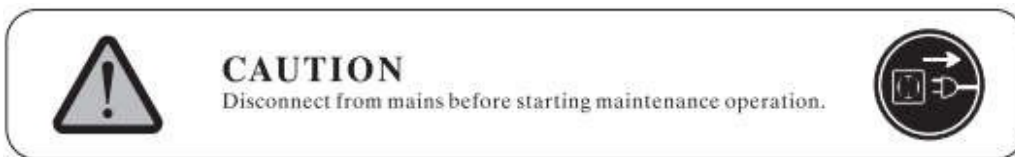

In order to make the lights in good condition and extend the life time, we suggest a regular cleaning to the lights.

1) Clean the inside and outside lens each week to avoid the weakness of the lights due to accumulation of dust.

2) Clean the fan each week.

3) A detailed electric check by approved electrical engineer each three month, make sure that the circuit contacts are in good condition, prevent the poor contact of circuit from overheating.

We recommend a frequent cleaning of the device. Please use a moist, lint-free cloth. Never use alcohol solvents.

There are no serviceable parts inside the device. Please refer to the instructions under "Installation instructions".

Should you need any spare parts, please order genuine parts from your local dealer.

Troubleshooting Problems

The following are a few common problems that may occur during operation. Here are some suggestions for easy troubleshooting:

A. The unit does not work:

- Check that the unit is plugged in to a working power connector.
- Press the menu button to confirm that the unit is powered on. If the screen does not light up, the unit has no power.

B. Not Responding to the DMX Controller

- Check DMX cables to verify that they are plugged in and functional.
- Check the DMX address and mode – does it match the address and mode patched in the lighting console or software?
- Plug the light directly into the DMX controller with a cable that you know is good. Unplug all other lights – does it work?
- Try to use another DMX controller.

4. Technical Specifications

- Input Voltage: AC90-260V 50/60Hz
- Light Source: 250W High Output White LED
- Control Signal: DMX 512, master-slave and sound activated or auto operation
Control Channel: 16/18 DMX Channels USITT DMX-512
- Power Consumption: 250w Dimensions: 270(D)*270(W)*470(H)mm
- Packaging Size: 305(D)*305(W)*500(H)mm
- Net Weight: 13.5kg



Photometric Data

